

Model GP-2000

PRESSURE REDUCING VALVE

Installation & Operation Manual

Please read this bulletin thoroughly before using the pressure reducing valve, so that you may do so correctly and safely. Please carefully store this bulletin in a handy place.

—————The following safety symbols are used in this manual. —————

 **Warning**

This symbol indicates a potentially hazardous situation that, if not avoided, could result in death or serious injury.

 **Caution**

This symbol indicates a hazardous situation that, if not avoided, may result in minor or moderate injury. ("Caution" may also be used to indicate other unsafe practices or risks of property damage.)

Contents

1. Features	1
2. Specifications	1
3. Dimensions and Weights	2
4. Operation	3
5. Nominal Size Selection Method	
5.1 Specifications selection chart	7
5.2 Safety valve setting pressure chart	7
5.3 Characteristics chart	7
5.4 Nominal size selection chart	8
5.5 Nominal size selection calculation formula	9
6. Installation	
6.1 Example of piping	9
6.2 Precautions during installation	10
6.3 Installing accessories	11
6.4 Sensing pipe connection method	11
7. Operating Procedure	
7.1 Precautions during operation	11
7.2 Adjustment procedures	12
8. Maintenance Procedure	
8.1 Troubleshooting	12
8.2 Precautions during maintenance and inspection	13
8.3 Disassembly	14
8.4 Precautions during reassembly	14
8.5 Exploded drawing	15, 16
After Sale Service	



1. Features

GP-2000 pressure reducing valves for steam are pilot-operated valves which can be used with confidence for small to large flow rate, in a host of applications ranging from building utilities systems, air-conditioning systems, and factory systems, etc.

2. Specifications

2.1 Models

Model	Nominal pressure	Connection	Nominal size	Pilot type
GP-2000	2.0 MPa	Screwed	15-50A	Integral mount (or Remote mount)
	1.0 MPa	Flanged	15-200A	
GPP-2000	Pilot valve (common for screwed and flanged valves of all nominal sizes)			
GPM-2000	Main valve (Screwed and flanged)			

2.2 Specifications

Model	GP-2000		
Reduced pressure sensing method (*1)	External sensing		
Connection	JIS Rc Screw	Flanged (JIS 20K RF)	Flanged (JIS 10K FF)
Nominal size	15~50A	15~200A	
Fluid	Steam		
Inlet pressure	0.1~2.0 MPa		0.1~1.0 MPa
Reduced pressure (*2)	0.02~0.15 MPa (Yellow)		0.02~0.15 MPa (Yellow)
	0.1 ~1.4 MPa (Green)		0.1 ~0.85 MPa (Green)
	85% or less of inlet pressure (gauge pressure)		
Min. differential pressure	0.05 MPa		
Max. pressure reducing ratio	20:1		
Max. temperature	220°C		
Valve seat leakage	0.01% or less of rated flow		
Material	Body	Ductile Cast iron	
	Valve	Stainless steel	
	Valve seat	Stainless steel	
	Diaphragm	Stainless steel	
	Gasket	Non asbestos	
Body hydraulic test	4.0 MPa	2.0 MPa	

* Optional valves (Cv value varies.) [15-100A]

- (1) For reduced pressure sensing method, internal sensing method valves will be available upon request.
- (2) Valves with outlet pressure of 0.01~0.02 MPa will be available upon request.
(Inlet pressure: 0.06~0.5 MPa, Max. pressure reducing ratio: 50:1)

Caution

- (1) Please collate with attached nameplate and specification of ordered model.
※Please consult factory in case they do not match each other.

3. Dimensions and Weights

3-1. GP-2000 (Integral mount type)

- The structure differs for nominal sizes 50A to 100A.

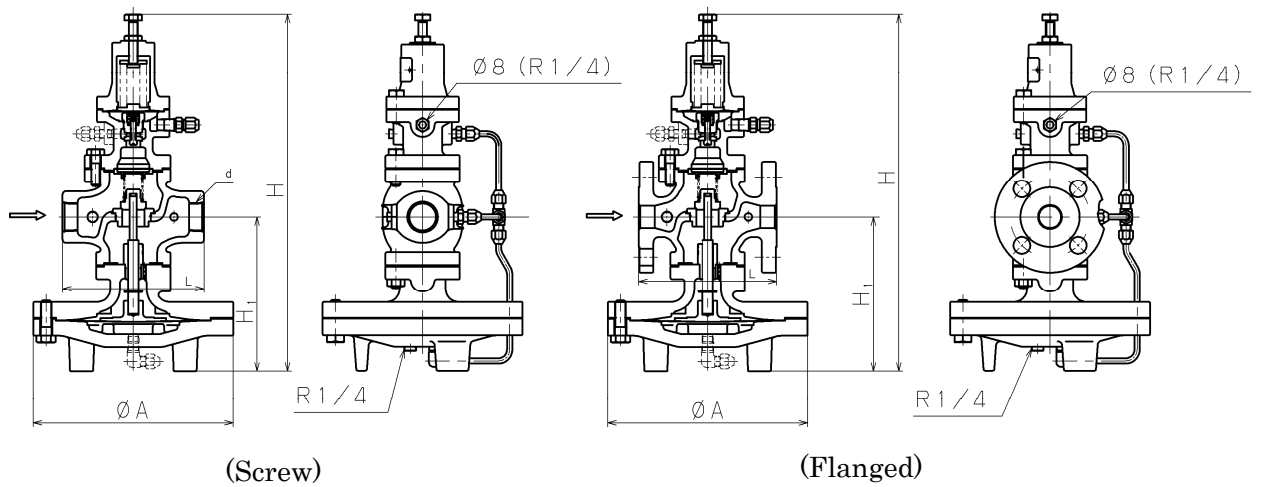

(mm)

Size	Screw (JIS Rc)						Flanged (JIS 20KRF)				
	d	L	H	H ₁	A	Weight (kg)	L	H	H ₁	A	Weight (kg)
15A	Rc 1/2	150	398	170	200	14.0	146	398	170	200	15.5
20A	Rc 3/4	155	398	170	200	14.0	146	398	170	200	16.0
25A	Rc 1	160	404	175	226	18.5	156	404	175	226	21.0
32A	Rc 1-1/4	190	434	192	226	21.5	176	434	192	226	24.0
40A	Rc 1-1/2	190	434	192	226	21.5	196	434	192	226	24.5
50A	Rc 2	220	498	216	276	33.0	222	498	216	276	36.0
65A	—	—	—	—	—	—	282	552	251	352	64.5
80A	—	—	—	—	—	—	302	572	264	352	71.5
100A	—	—	—	—	—	—	342	658	321	401	111
125A	—	—	—	—	—	—	400	658	321	401	115
150A	—	—	—	—	—	—	465	814	414	502	234
200A	—	—	—	—	—	—	469	814	414	502	242

* Different Length (L) and Weight values apply for JIS 10K FF.

3-2. GP-2000 (Remote mount type)

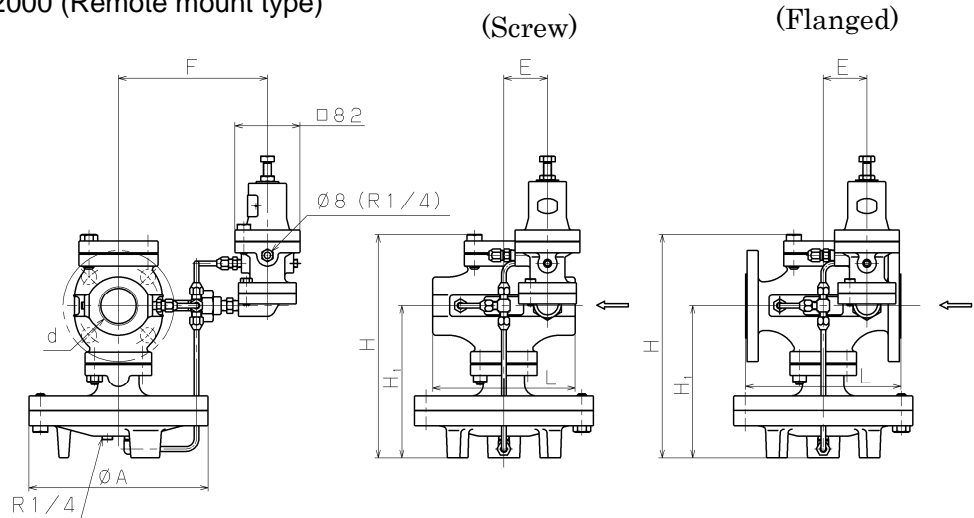

- The structure differs for nominal sizes 50A to 100A.

Screw (JIS Rc)

(mm)

Size	d	L	H	H ₁	A	E	F	Weight (kg)
15A	Rc 1/2	150	398	170	200	45	175	15.5
20A	Rc 3/4	155	398	170	200	45	175	15.5
25A	Rc 1	160	404	175	226	46	180	20.0
32A	Rc 1-1/4	190	434	192	226	55	188	23.0
40A	Rc 1-1/2	190	434	192	226	55	188	23.0
50A	Rc 2	220	498	216	276	65	195	34.0

Flanged (JIS 20KRF)

(mm)

Size	L	H	H ₁	A	E	F	Weight (kg)
15A	146	398	170	200	45	175	15.5
20A	146	398	170	200	45	175	15.5
25A	156	404	175	226	46	180	20.0
32A	176	434	192	226	55	188	23.0
40A	196	434	192	226	55	188	23.0
50A	222	498	216	276	65	195	34.0
65A	282	552	251	352	75	212	64.8
80A	302	572	264	352	80	223	71.3
100A	342	658	321	401	105	240	111
125A	400	658	321	401	130	240	115
150A	465	814	414	502	150	289	234
200A	469	814	414	502	150	289	242

* Different Length (L) and Weight values apply for JIS 10K FF.

3-3. GPP-2000 Remote mount type (Pilot valve)

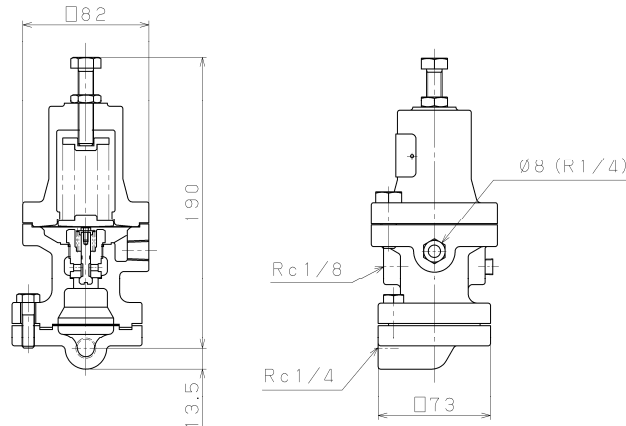

3-3. GPM-2000 Remote mount type (Main valve)

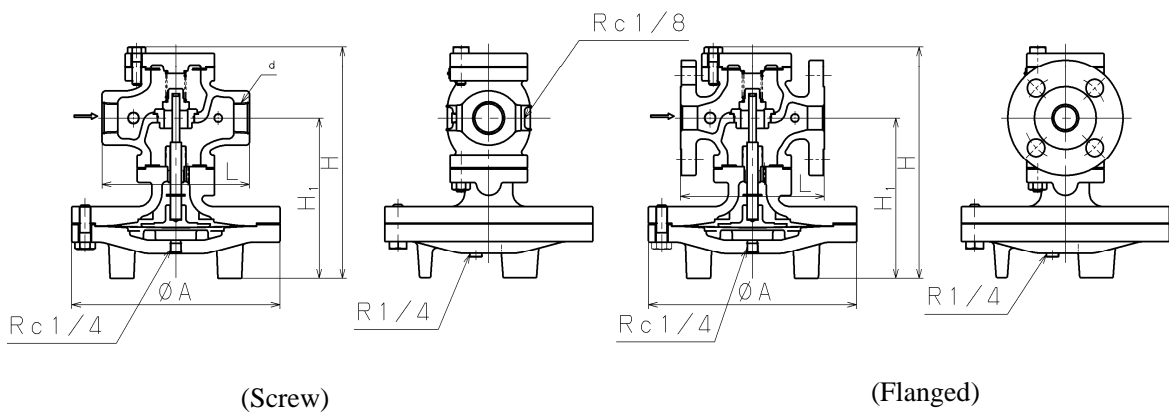

(Screw)

(Flanged)

4. Operation

The pressure reducing valve reduces pressure by the throttling the valve. The valve is composed of the main valve and main valve seat for throttling, and adjusting spring, diaphragm, pilot valve, and piston for pressure sensing and activation.

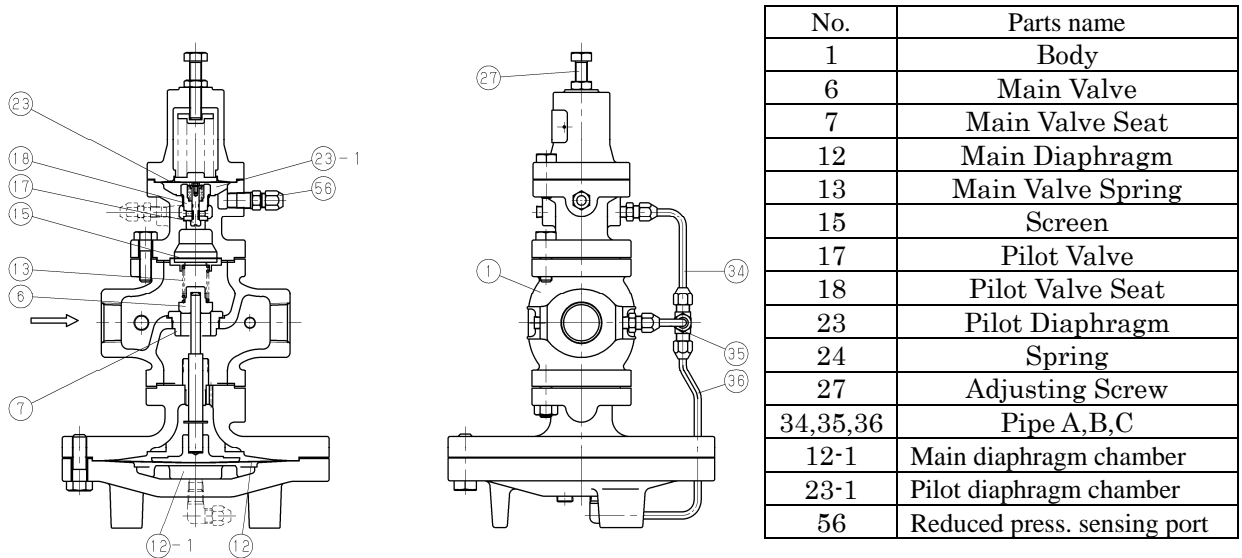

- (1) When the pressure reducing valve is mounted correctly, releasing the compression of adjusting spring [24] allows main valve spring [13] and pilot valve spring [19] to close main valve [6] and pilot valve [17]. Slowly open the gate valve and allow the high pressure fluid to flow in. Inlet pressure is applied to the upside of the main valve. High pressure fluid passes through screen [15] to also apply inlet pressure to the downside of the pilot valve. (**Fig. 1**)

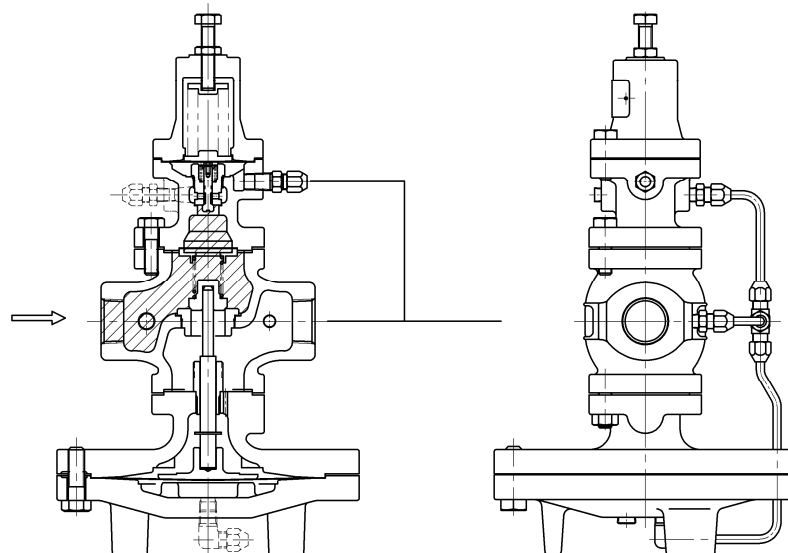

Fig. 1

- (2) Turning adjusting screw [27] clockwise compresses the spring, which flexes pilot diaphragm [23] to open the pilot valve. The fluid passing through pilot valve [17] and pilot valve seat [18] enters the main diaphragm chamber via pipes A [34] and C [36]. This fluid also flows to the reduced side of the body [1] through pipe B [35] and the orifice of joint B [31] that connects to the body. (Fig. 2)

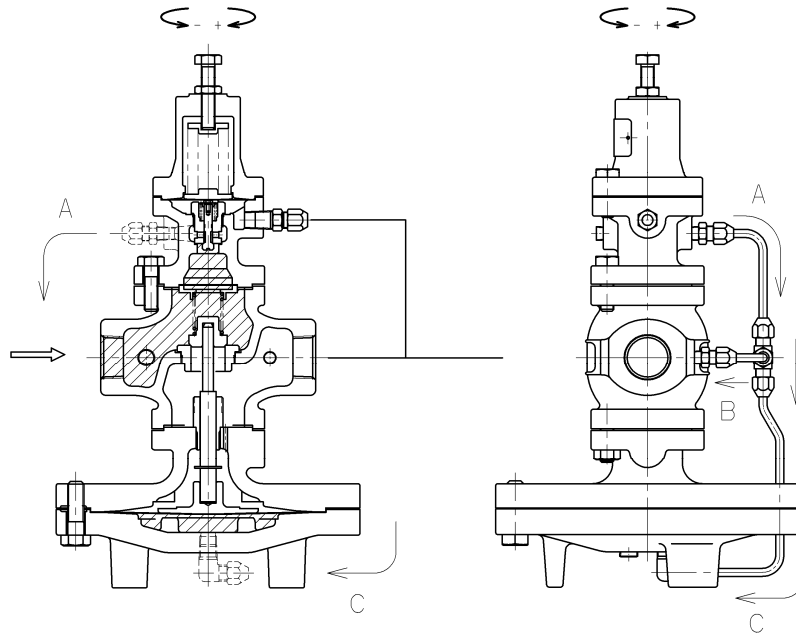

Fig. 2

- (3) When the flow rate at the pilot valve exceeds the flow rate at the orifice, operating pressure in the main diaphragm chamber raised and overrides the pressure on the upside of the main valve and the load of main valve spring [13] to open the main valve. The fluid then begins to flow from the inlet side. (Fig. 3)

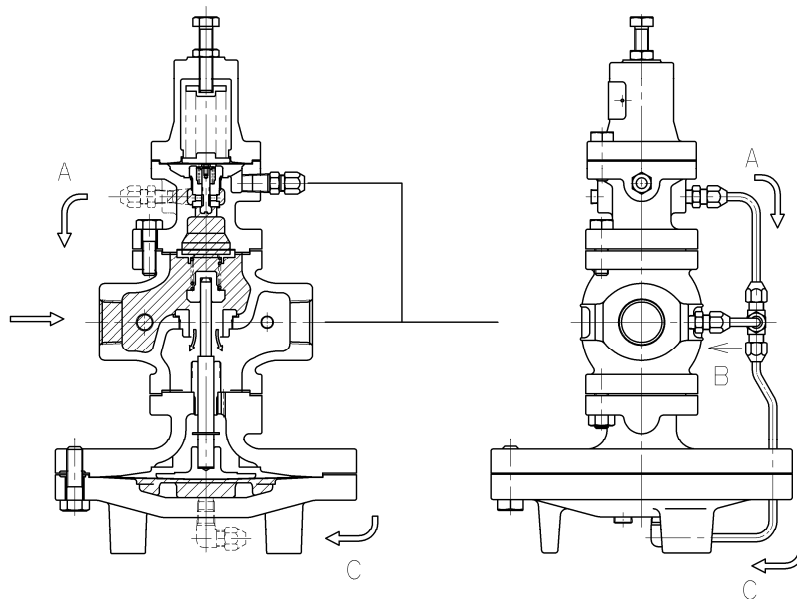

Fig. 3

- (4) Reduced pressure is led to the pilot diaphragm chamber [23]-1 via the sensing pipe and reduced pressure sensing port [56]. The pilot diaphragm receives the reduced pressure to be balanced with the spring load. The pilot valve travel is controlled by the spring load and pressure applied to the pilot diaphragm due to variations in reduced pressure. This changes the flow rate of fluid to the main diaphragm chamber, which controls the main valve travel to obtain appropriate reduced pressure. (Fig. 4)

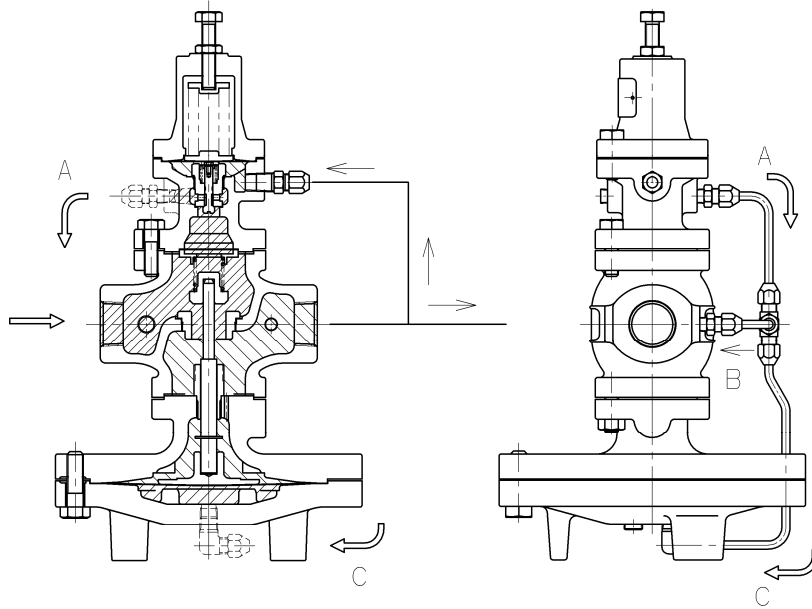

Fig. 4

- (5) When the load on the reduced side is released, pressure in the pilot diaphragm chamber raises to close the pilot valve. Operating pressure in the main diaphragm chamber is released to the body via the orifice, and the main valve spring presses the main valve to close. (Fig. 5)

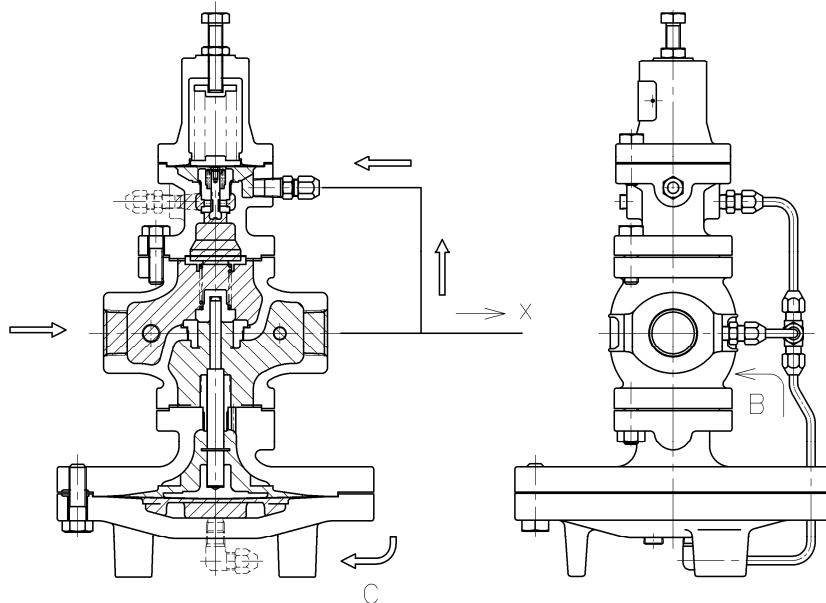
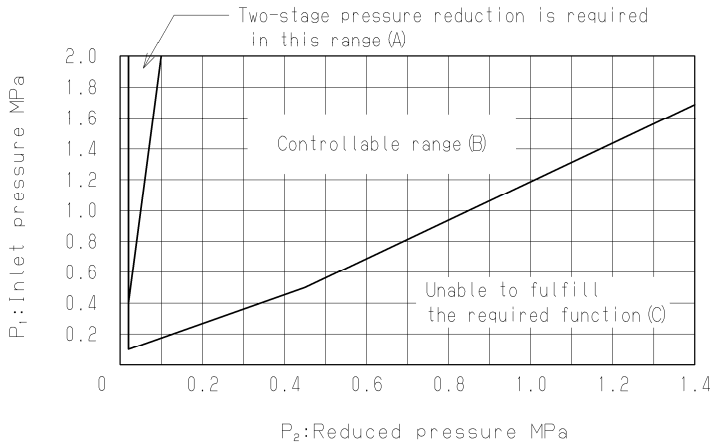

Fig. 5

5. Nominal Size Selection Method

5.1 Pressure reducing valve specification selection chart



Refer to the above selection chart to select the most appropriate pressure reducing valve. Find the point of intersection of inlet pressure (P_1) and reduced pressure (P_2). When the point of intersection is within range (A), reduce pressure in two stages. When within range (C), maximum performance cannot be obtained. When reducing pressure in two stages, maximize the distance between the valves (at least 3 m).

5.2 Safety valve setting pressure chart

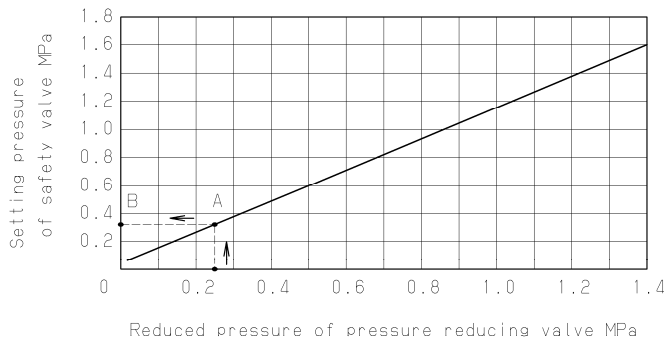

Determine the reduced pressure of pressure reducing valve. Find the intersection point (A) with the chart curve. Next, find point (B) by proceeds horizontally from point (A) to the left until the 'Setting pressure of safety valve' axis. The setting pressure of the safety valve should be higher than the pressure of the point (B).

5.3 Characteristics chart

(1) Flow rate characteristics chart

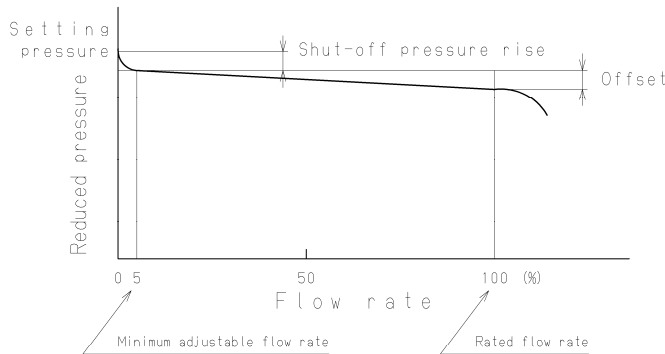

- Shut-off pressure raise : 0.02 MPa or less
- Offset : 10% or less of setting pressure (Minimum value: 0.02MPa)

(2) Pressure characteristics chart

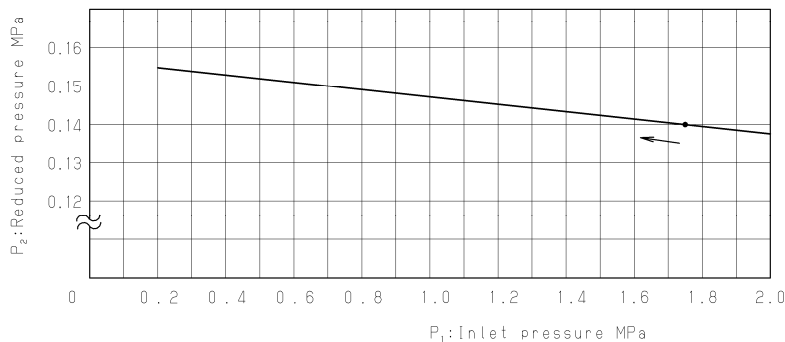

Reduced pressure is set to 0.14 MPa when inlet pressure is 1.75 MPa. The chart indicates a variation in reduced pressure when the inlet pressure is changed from 0.2 to 2.0 MPa.

5.4 Nominal size selection chart

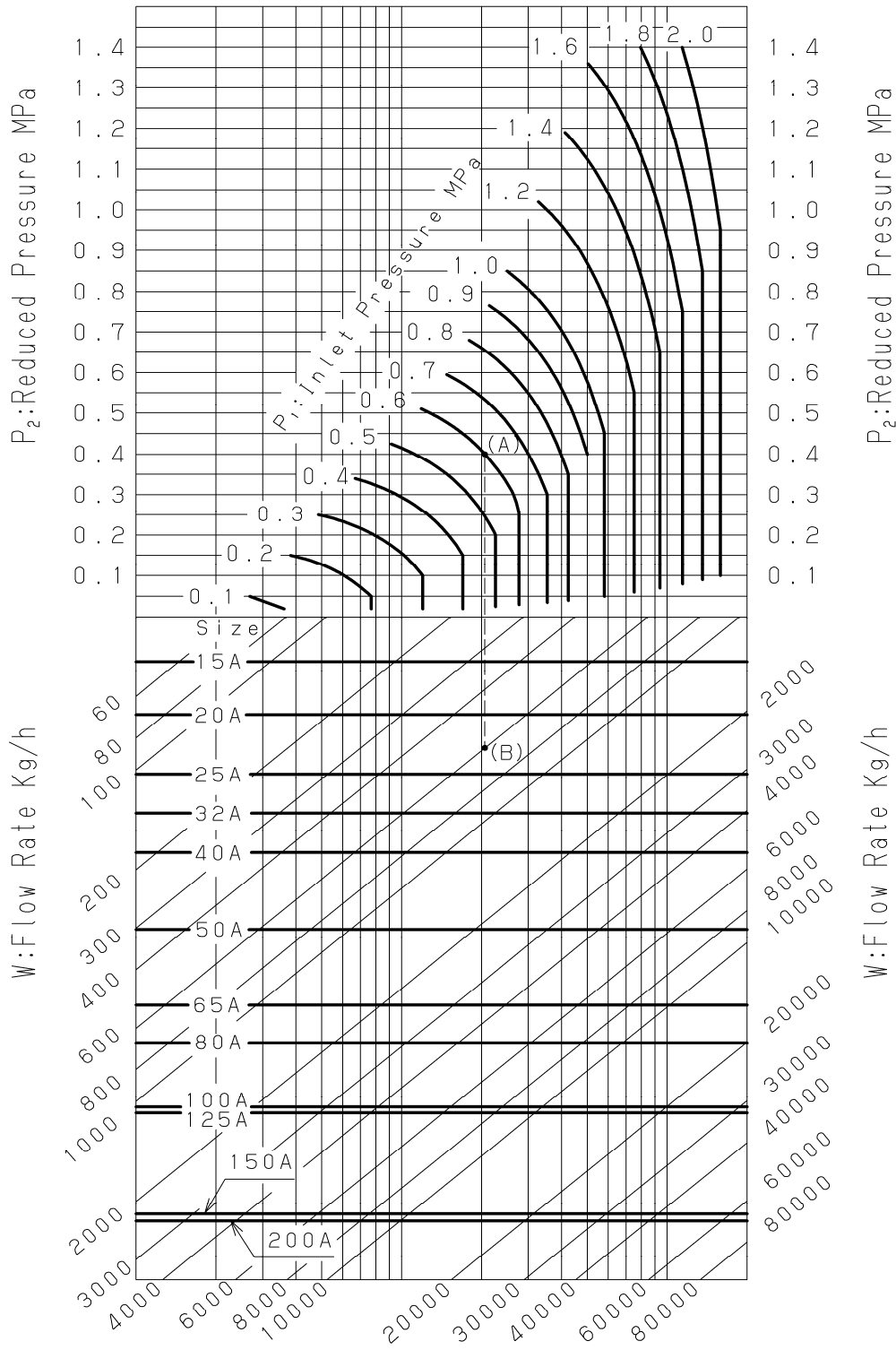

For example, take a pressure reducing valve whose inlet pressure (P₁) is 0.6 MPa, reduced pressure (P₂) 0.4 MPa, flow rate 600 kg/h. When determining the nominal size, find the point of intersection (A) of inlet pressure 0.6 MPa and reduced pressure 0.4 MPa. Vertically proceed from point (A) to come across the flow rate 600 kg/h, and regard this point as (B). Point (B) is between nominal sizes 20A and 25A. Select the larger nominal size (in this example, nominal size 25A)

5.5 Nominal size selection calculation formula

The appropriate nominal size can be calculated by obtaining the Cv value for the operating conditions in question, as shown below.

• Cv value calculation formula

$$P_2 > \frac{P_1}{2}$$

$$C_v = \frac{Wk}{138\sqrt{\Delta P(P_1 + P_2)}}$$

$$P_2 \leq \frac{P_1}{2}$$

$$C_v = \frac{Wk}{120P_1}$$

W: Max. steam flow rate [kg/h]

P₁: Inlet pressure [MPa · A]

P₂: Reduced pressure [MPa · A]

Δ P: P₁ - P₂ [MPa]

k: 1+0.0013 × {super-heated steam temp.[°C] - saturated steam temp.[°C]}

• Rated Cv value table

Nominal size	15A	20A	25A	32A	40A	50A	65A	80A	100A	125A	150A	200A
Rated Cv value	5	7.2	10.9	14.3	18.8	32	54	70	108	112	225	234
0.01 MPa set	2.5	3.6	5.4	7.1	9.4	16	27	35	54	-----	-----	-----

*Please consults factory for internal sensing method valves.

[Flow rate calculation example of GP-2000 pressure reducing valve]

The flow rate of the pressure reducing valve is calculated under the following conditions: Nominal size 15A, saturated steam, Inlet pressure of 0.6 MPa, Reduced pressure of 0.4 MPa. P₁=0.7 [MPa A], P₂=0.5 [MPa A], you can find that Cv value of 15A is 5 from the chart. The following formula is established.

$$P_2 (= 0.5) > \frac{P_1 (= 0.7)}{2} \quad W = \frac{138C_v\sqrt{\Delta P(P_1 + P_2)}}{k}$$

$$W = \frac{13.5C_v\sqrt{\Delta P(P_1 + P_2)}}{k} = \frac{138 \times 5 \times \sqrt{0.2 \times (0.7 + 0.5)}}{1} = \underline{\underline{338kg / h}}$$

■ Secure a safety rate of 80 to 90%

6. Installation

6.1 Example of piping

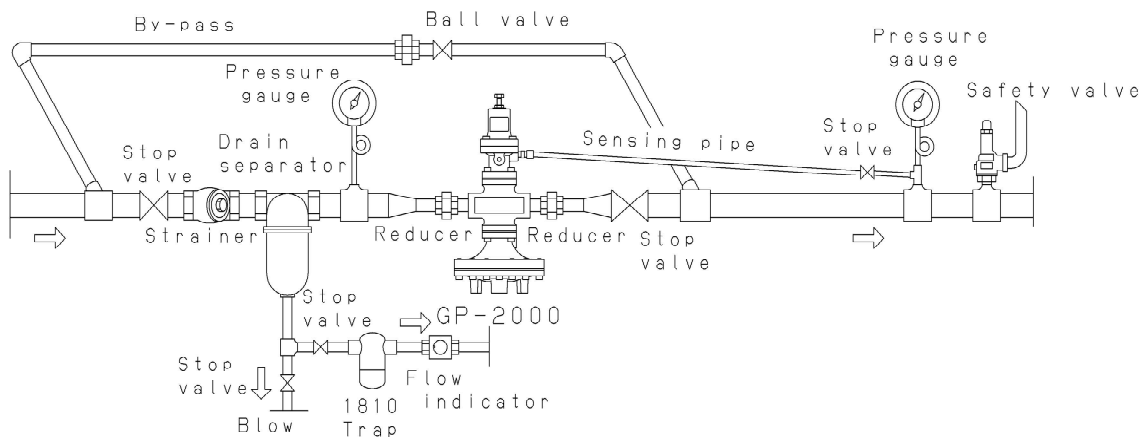

6.2 Precautions during installation

⚠ Warning

- (1) Because of heavy weight, hold the valve with lifting equipment while piping. Refer to “**3. Dimensions and weights**” table for the valve weight.
 ※Failure to do so may result in injury due to dropping the valve.
- (2) In case installing safety valve as safety device at outlet side, joint relief pipe at outlet of safety valve and guide it to safety place where steam can relief out.
 ※Failure to do so may result in burns.

⚠ Caution

- (1) Do not disassemble the valve unreasonably.
 ※Disassembling the valve at your discretion may affect the original performance.
- (2) Remove foreign matter and scales from the lines before connecting the valve.
 ※Failure to do so may prevent the valve from functioning correctly.
- (3) Install a strainer (Recommendation: 80-100mesh or close) at the valve inlet side.
 ※Failure to do so may hamper correct pressure control, which affects the original performance.
- (4) Install a safety valve at the valve outlet sides as safety device for equipment.
 ※Failure to do so prevents problem identification, resulting in equipment damage.
- (5) Install a pressure gauge at both the inlet and outlet sides of the valve.
 ※Failure to do so may hamper correct pressure adjustment.
- (6) Install a steam trap to the inlet sides of the valve to prevent drainage problems.
 ※Failure to do so may result in drainage problem, affecting the original performance.
- (7) When installing quick open and close valves, such as a solenoid valve, install it at inlet side as much as possible, and secure at least 3 m from the valve.
 ※Failure to do so may result in malfunction or drastically shortened service life.
- (8) When pressure reducing in two stages, secure at least 3 m between the valves.
 ※Failure to do so may result in malfunction, affecting the original performance.
- (9) Install the valve in proper direction of the fluid flow.
 ※Failure to do so may affect the original performance.
- (10) Do not apply excessive load, torque or vibration to the valve.
 ※Doing so may result in malfunction or drastically shortened service life.

- (1) Install the valve perpendicularly to horizontal lines.
- (2) Provide the by-pass line. (See 6.1 Example of piping)
- (3) When the pressure reducing ratio is large, install a reducer to keep the flow velocity in the pipe below 30 m/s or less.
- (4) Provide space on the top and bottom of the valve so that the valve can be easily disassembled and inspected. (See **Fig.6**)

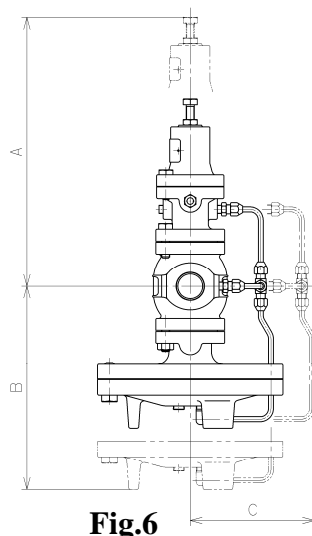

Fig.6

(mm)

Nominal size	A	B	C
15A	300	340	180
20A		350	200
25A			
32A	320	380	220
40A			
50A	360	430	
65A	380	370	260
80A	390	390	
100A	410	470	280
125A			
150A	620	740	340
200A			

6.3 Installing accessories

Warning

- (1) When installing the pressure reducing valve, be sure to connect the provided sensing pipe and joint.
※Unless the sensing pipe is connected, the valve will not operate. Further, steam may blow off, resulting in burns.

6.4 Sensing pipe connection method

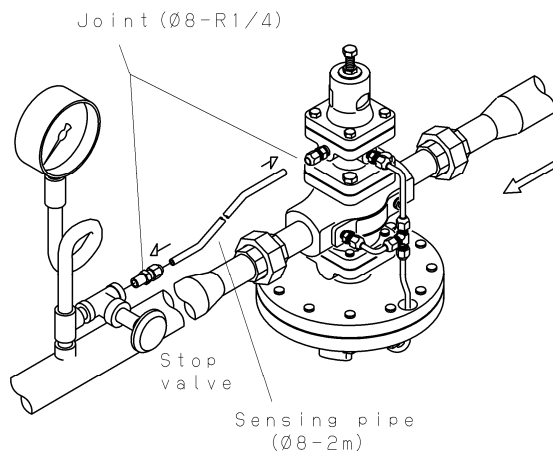

Fig.7

Connect the provided sensing pipe (ϕ 8-2m) and joint (ϕ 8-R1/4) as shown in the illustration on the left.

1. Wind sealing tapes around the joint and insert the joint into the pressure sensing side.
2. Fully insert the sensing pipe into the valve and the pressure sensing side joint. Tighten the cap nut until it can no longer be rotated manually, and then turn the cap nut about one and quarter times with a tool. Note that the sensing pipe must be connected so that the valve side is higher than the pressure sensing side.

7. Operating Procedure

7.1 Precautions during operation

Warning

- (1) Do not touch the valve directly with bare hands.
※Doing so may result in burns.
- (2) Before flow the steam in pipe line, make sure steam can flow without any dangerous at the end of pipe line and pipe line is connected tightly.
※In case steam blow off, it may result in burns.

Caution

- (1) Close the stop valves before and after the pressure reducing valve, and remove all foreign matter and scales via the by-pass line before operation. And, open each stop valve slowly.
※Failure to do so may prevent the valve from functioning correctly. And, It may cause hunting, water hammer, etc., resulting in damage to the valve and other equipment when the stop valve is opened quickly.
- (2) Secondary pressure at by-pass line must be lower than set pressure.
※Safety valve blows in case secondary pressure at by-pass line becomes higher than set pressure.
- (3) When adjusting pressure, slowly turn the adjusting screw
※Incorrect adjustment may cause hunting, water hammer, etc., resulting in damage to the valve and other equipment.
- (4) Remove condensate completely from the line, and close the stop valves before and after the valve when not using it for long periods of times.
※Rust generated in the valves and lines may cause malfunction.

7.2 Adjustment

Follow the steps below, and slowly turn the adjusting screw to set pressure. Incorrect adjustment may cause hunting, water hammer, etc., resulting in damage to the valve and other equipment. (See 6.1 Example of piping.)

- (1) Check that all stop valves (V_1 to V_7) are closed.
- (2) Open the stop valve (V_6) for the trap installed before the pressure reducing valve.
- (3) Open the stop valve (V_3) and adjust the valve travel of the by-pass line glove valve (V_5). Taking sufficient time not to blow the safety valve, blow off the fluid to remove foreign matter. After blowing, close the by-pass line glove valve.
- (4) Loosen lock nut [28] and turn adjusting screw [27] counterclockwise to release spring [24] (no compression).
- (5) Open the sensing pipe stop valve (V_4).
- (6) Open the stop valve (V_2) at the outlet side of the pressure reducing valve. Adjust the travel of the stop valve (V_3) so that a little fluid flows.
- (7) Confirm that the condensation is discharged from the inside of the pressure reducing valve, and slowly open the stop valve (V_1) on the inlet side.
- (8) Slowly turn the adjusting screw clockwise while observing the pressure gauge on the outlet side, and set the desired pressure.
- (9) When the entire system has stabilized, conduct fine adjustment as necessary.
- (10) After adjustment, tighten the lock nut.
- (11) Check for leakage. Conduct re-tightening as necessary.

8. Maintenance Procedure

8.1 Troubleshooting

Problem	Cause	Solution
Pressure does not reach the desired value.	<ol style="list-style-type: none"> 1. Incorrect pressure is being used. 2. Screen [15] is clogged. 3. Main diaphragm [12] is damaged 4. Orifice of tee [33] is clogged. 5. Pilot valve [17] and pilot valve seat [18] are clogged with foreign matter, scales, etc. 6. Sensing pipe is clogged. 7. Nominal size is too small for the specifications. 8. Pressure is not adjusted correctly. 9. Wrong installation with tee [33] 10. Strainer installed before pressure reducing valve is clogged. 11. Pressure gauge is faulty. 	<ol style="list-style-type: none"> 1. Correct the pressure. 2. Disassemble and clean the screen. 3. Remove pipe C [36] at elbow [32] and open the by-pass valve. If the fluid runs out from elbow, replace the main diaphragm. 4. Remove the orifice and clean it. 5. Disassemble pilot valve assembly, and clean it. 6. Disassemble and clean it. 7. Change the nominal size appropriately. 8. Observe the adjustment procedures and readjust pressure. 9. Install the tee whose slit should be faced upward (Refer to Fig.10). 10. Disassemble and clean it. 11. Replace it.
Reduced pressure raises above than the specified value.	<ol style="list-style-type: none"> 1. Foreign matter exists between main valve [11] and main valve seat [12], or scratches exist. 	<ol style="list-style-type: none"> 1. Disassemble and remove the foreign matter. When any scratches are identified, lap the main valve and main valve seat. Change the parts if scratches still exist after lapping.

Problem	Cause	Solution
Reduced pressure raises above than the specified value.	2. Foreign matter exists between pilot valve and pilot valve seat, or scratches exist. 3. Orifice of tee is clogged. 4. Reduced pressure is not adjusted correctly. 5. Trap is not provided for dead-end line. 6. By-pass valve is leaking. 7. Pilot diaphragm [23] is damaged.	2. Disassemble the pilot valve assembly, and clean or replace it. 3. Remove the orifice and clean it. 4. Observe the adjustment steps and readjust pressure. 5. Install a trap. 6. Repair or replace it. 7. Replace the pilot diaphragm.
Abnormal noise is heard.	1. Nominal size is too large for the specifications. 2. Pressure reducing ratio is too large. 3. Drainage problem is caused. 4. An abrupt OPEN/CLOSE valve is located too close to the pressure reducing valve. 5. Outlet pipe is too small.	1. Change the nominal size appropriately. 2. Reduce pressure in two stages. 3. Install a trap. 4. Allow as much as possible between the valves. 5. Select a pipe size that will produce a flow velocity of 30m/s or less.

- Foreign matter and scales in a pipe may cause most of problems of pressure reducing valve. Be careful sufficiently to foreign matter in a pipe.
- Phenomenon alike valve trouble may happen by fault of pressure gauge, fluid leakage from by-pass valve, forgetting to close the by-pass valve, clogging strainer, and etc. First, check the said particulars before above troubleshooting.
- Consult factory when cannot make a judgement whether parts need replacement or not.

8.2 Precautions during maintenance and inspection

Warning

- (1) Completely discharge internal pressure from the valves, lines, and equipment, and cool the valve down to a level where you can touch it with bare hands before disassembly and inspection.
 ※ Failure to do so may result in injury or burns due to residual pressure or spillage around the valve.

Caution

- (1) In order to maintain original performance and function, examine daily and personal inspection. And, periodical inspection must be examined according to the regulations of every kind.
 ※ For general users, request to specialized dealer or manufacture.
- (2) Pressure reducing valve shall be disassembled and inspected by qualified person or manufacture.
 ※ Request the treatment to specialized dealer or manufacture in case of any problems.
- (3) While disassembly, drain flow out from the valve, so catch it by container. And release steam completely before disassembling.
 ※ In case of no container for drain, it makes dirty surrounding the valve.
- (4) Close the stop valves before and after the pressure reducing valve, and remove all foreign matter and scales via the by-pass line before operation.
 ※ Failure to do so may prevent the valve from functioning correctly.
- (5) When adjusting pressure, slowly turn the adjusting screw.
 ※ Incorrect adjustment may cause hunting, water hammer, etc., resulting in damage to the valve and other equipment.

- (6) Remove condensate completely from the line, and close the stop valves before and after the valve when not using it for long periods of times.
 - ※ Rust generated in the valves and lines may cause malfunction.
- (7) In case of no operation for a long period of time, perform operating exam before start operation again.
 - ※ Request the treatment to specialized dealer or manufacture in case of any problems.

8.3 Disassembly

Be sure that the stop valves at inlet and outlet side of pressure reducing valve is closed and all internal pressure and condensate have discharged before disassembling the valve.

(1) Pilot valve

1. Slightly loosen lock nut [28] and turn adjusting screw [27] counterclockwise to release spring [24] (no compression).
2. Remove bolt [37] of spring chamber [3]. Remove the spring chamber, spring, top spring plate [25], bottom spring plate [26], and pilot diaphragm [23].
3. Remove pilot valve seat [18] (hexagonal section of the center of pilot body [2]) using a ring spanner or socket wrench (nominal size 22), and remove the entire pilot valve assembly.

(2) Main valve (15-125A)

1. Remove pipe A [34] at joint A [30] or tee [33].
2. For nominal sizes 15A to 40A, remove bolt [38] of pilot body [2]. Dismount the pilot body from the body [1]. And remove spring plate [14], screen [15], main valve spring [13], and main valve [6]. For nominal sizes 50A to 125A, remove bolt [44] of spacer [54] and remove the spacer from the main body [1], main valve spring [13], and entire main valve ([6], [9], [50], and [51]) (for nominal size 50A, main valve spring [13], and main valve [6]).

(3) Main diaphragm

1. Remove pipe C [36] at tee [33].
2. Remove bolt [41] of bottom dia. case [5]. Dismount the bottom dia. case, main diaphragm [12], retainer [11], and spindle [9] (adapter [52] and retainer [11] for nominal sizes 65A to 125 A).

8.4 Precautions during disassembly

Caution

- (1) Check that there is no damage and scratches on the main valve, main valve seat, pilot valve, and pilot valve seat.
 - ※ Any scratches at sealing surface lead to increase in secondary pressure. When any scratches are identified at main valve and seat, polish them away. And, change the parts if scratches still exist after polishing. Also, in case any scratches are identified at pilot valve and pilot valve seat, change into pilot valve assembly.
- (2) Move the sliding section (pilot valve, piston, etc.) two to three times and confirm they move smoothly.
 - ※ If the sliding parts do not move correctly, it may cause failure problems. (Working not correctly).
- (3) Replace gaskets with new ones when reassembling.
 - ※ If the gasket is used for a long time, it may cause steam leakage problem.
- (4) Assemble in the reverse order of Disassembly. And tighten the bolts evenly.
 - ※ Assemble the valve due to the order. Failure to do so may lead to not assemble correctly. And if the hexagon bolts are not screwed correctly, it may cause steam leakage problem.

8.5 Exploded drawing

For size 65A to 200A, refer to P.16

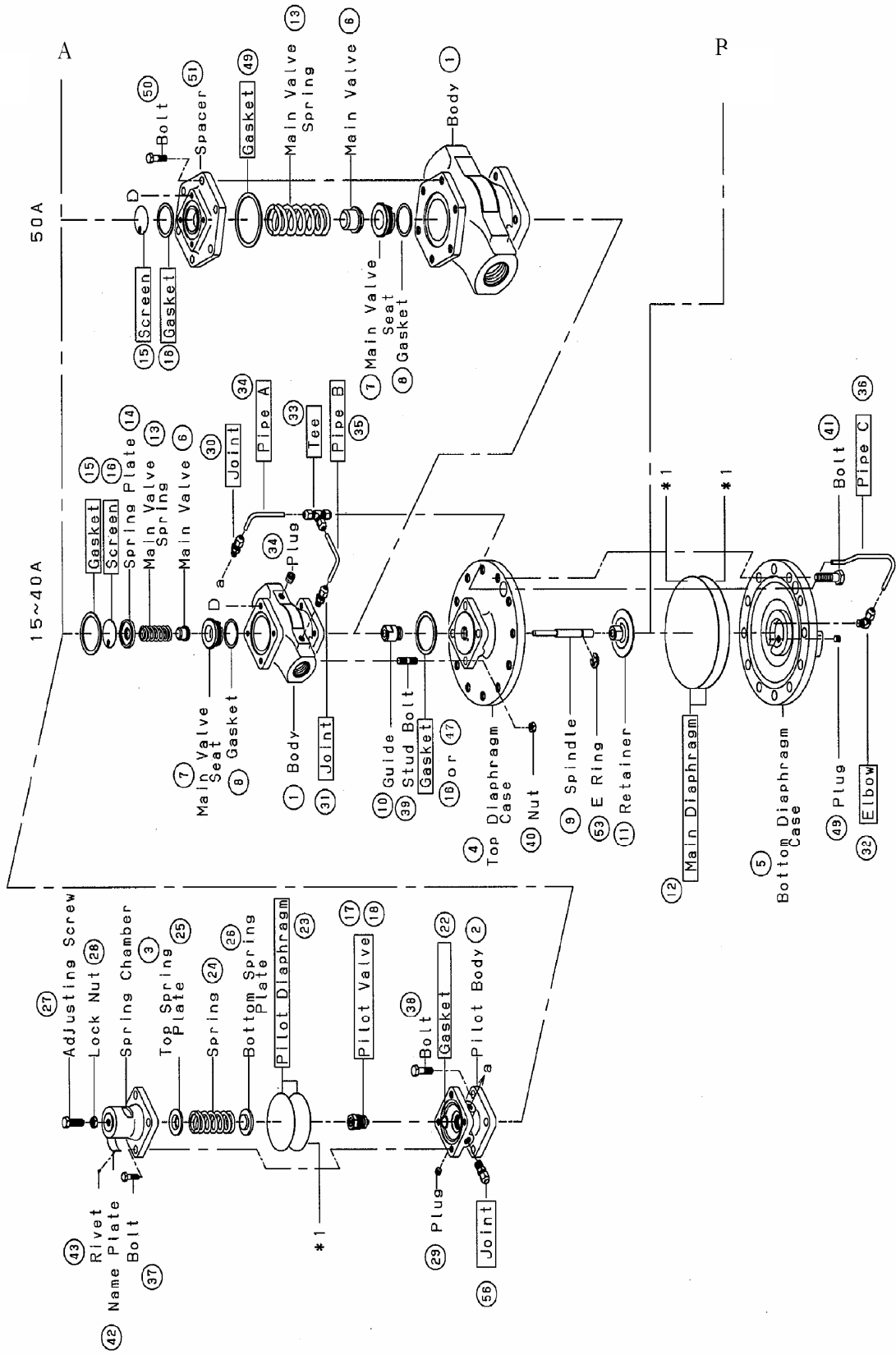

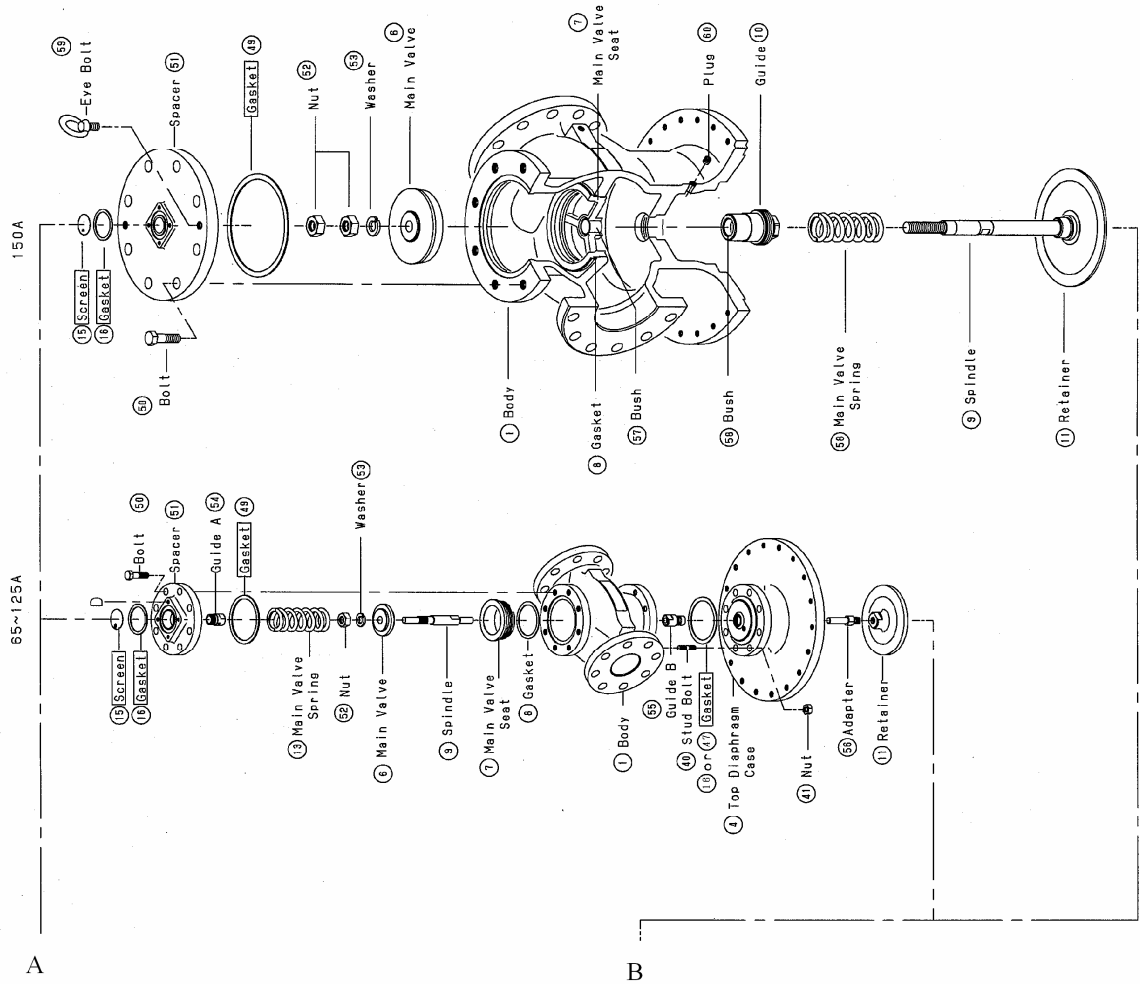

Parts within the flame are consumable. Please contact us for purchase of these consumable parts.

Note (*1): Apply a liquid sealant for heat and steam resistant (Recommendation: SOLVEST 110) to the sealing surface of the diaphragm bottom and the top cover.

(*2): For size 15A to 125A, attach the tee with turning upward the slit part. In addition, for size 150A and 200A, it is equipped with an orifice between tee and pipe B and pipe C respectively. Therefore, direction of tee is arbitrary. (Refer to following figure.)

