

# Model GD-20

## Pressure Reducing Valve

Please read this instruction manual thoroughly before using the pressure reducing valve, so that you may do so correctly and safely. Please carefully store this bulletin in a handy place.

—————The following safety symbols are used in this manual. —————

### **△Warning**

This symbol indicates a potentially hazardous situation that, if not avoided, could result in death or serious injury.

### **△Caution**

This symbol indicates a hazardous situation that, if not avoided, may result in minor or moderate injury. (“Caution” may also be used to indicate other unsafe practices or risks of property damage.)

## Contents

1. Features .....	1
2. Specifications & Performance	
2.1 Specifications .....	1
2.2 Flow Rate Characteristics Chart .....	2
2.3 Pressure Characteristics Chart .....	2
3. Dimensions & Weight .....	3
4. Operation .....	4
5. Nominal Size Selection Method	
5.1 Nominal Size Selection Chart .....	5~6
5.2 Selection Formula for Nominal Size .....	7
6. Installation	
6.1 Precautions before operation .....	8
6.2 Example of Piping .....	9
7. Operating Procedure	
7.1 Precautions for pressure reducing valve operation ..	9
7.2 Adjustment Procedure .....	10
8. Maintenance Procedure	
8.1 Troubleshooting .....	11
8.2 Precautions during disassembly and inspection .....	11
8.3 Disassembly .....	12
8.4 Precautions during disassembly .....	12
8.5 Exploded drawing .....	13
After Sales Service	

# **YOSHITAKE**

GD-20 pressure reducing valve is widely used for construction equipment, air conditioning, plant equipment, industrial plant facilities and other application. This product can provide stable outlet pressure and big capacity.

## 1. Features

- 1) As pressure balanced structure is introduced, outlet pressure can be kept at a constant level without influence of inlet pressure.
- 2) Rubber disc is used at the valve body to effectively eliminate leaks.
- 3) Maintenance is easy.

## 2. Specifications & Performance

### 2.1 Specifications

Model	GD-20(Stainless steel wetted parts)	GD-20(All stainless steel made)
Application (Fluid)	Cold and Hot water, Oil (kerosene, heavy oils A and B), Air, Other non-dangerous fluids	
Nominal size	15~100A	15~50A(*)
Inlet pressure	1.0MPa or less	
Reduced pressure	15A~80A 0.05~0.25MPa 0.26~0.7 MPa	15A~25A 0.05~0.2 MPa 0.21~0.6 MPa
	100A 0.05~0.25MPa 0.26~0.5 MPa	32A~50A 0.05~0.2 MPa 0.21~0.46 MPa
Min. differential pressure	0.05MPa	
Max. pressure reduction ratio	10:1	
Min. adjustable flow rate	Water: 5L/min Air : 10m <sup>3</sup> /h (Normal condition)	
Application temperature	5~80°C	
Coefficient of viscosity	600cSt or less	
Materials	Body	Cast Stainless Steel
	Valve Seat	Stainless Steel
	Valve Disc	NBR
	Diaphragm	NBR
Connection	JIS 10K FF Flanged	

(\*) Please contact us about availability of 65A to 100A.

### ⚠Caution

Please collate with attached nameplate and specification of ordered model.  
\*Please consult factory in case they do not match each other.

## 2.2 Flow Rate Characteristics Chart

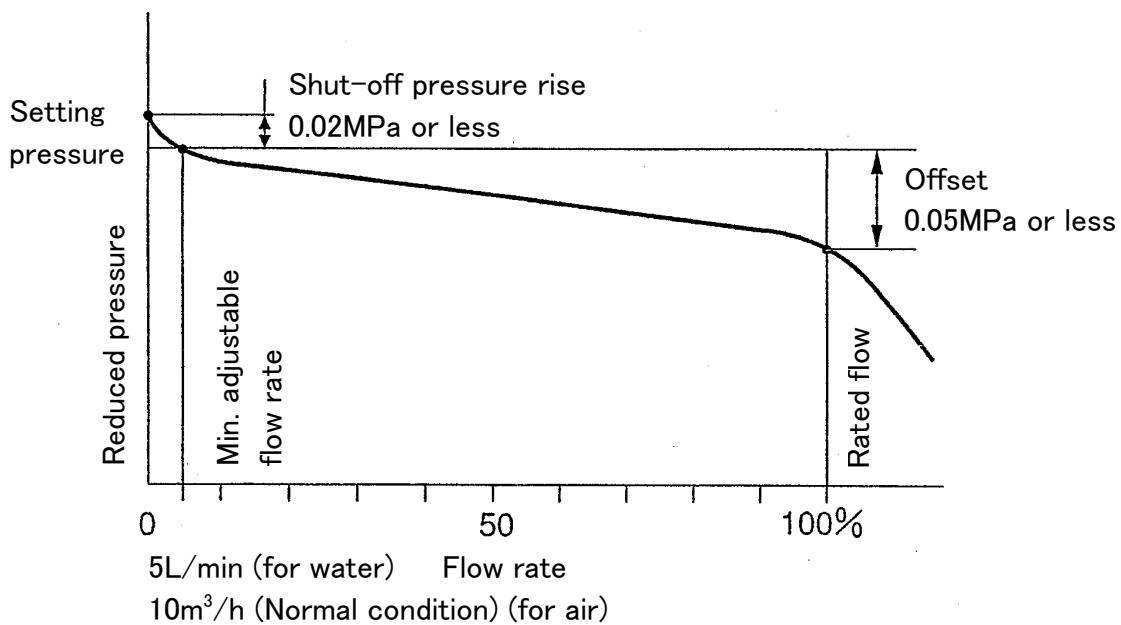

## 2.3 Pressure Characteristics Chart

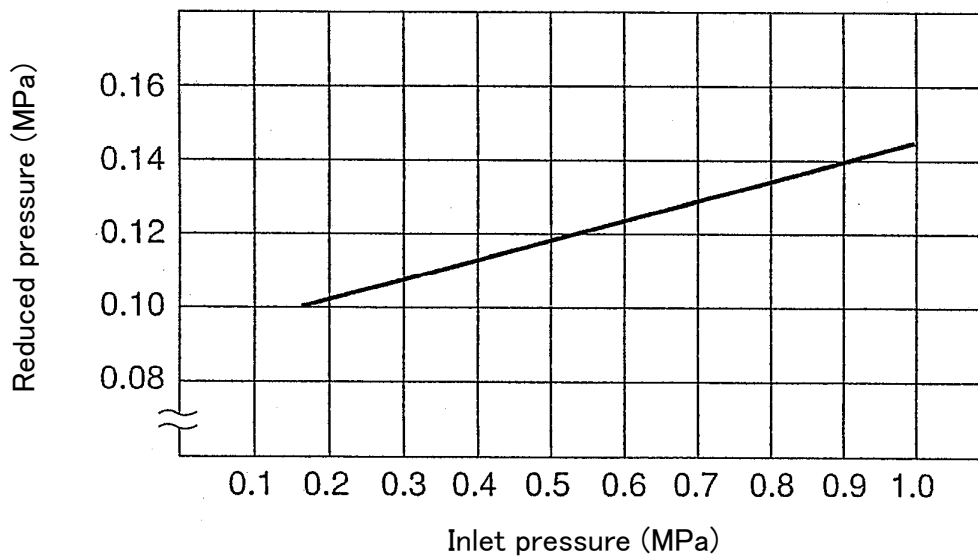

The above chart shows the change in the reduced pressure when the inlet pressure is changed in the range of 0.15~1.0~0.15 MPa whereas the reduced pressure is set at 0.1MPa at inlet pressure of 0.15MPa.

3. Dimension & Weight  
(Size 15~50A)

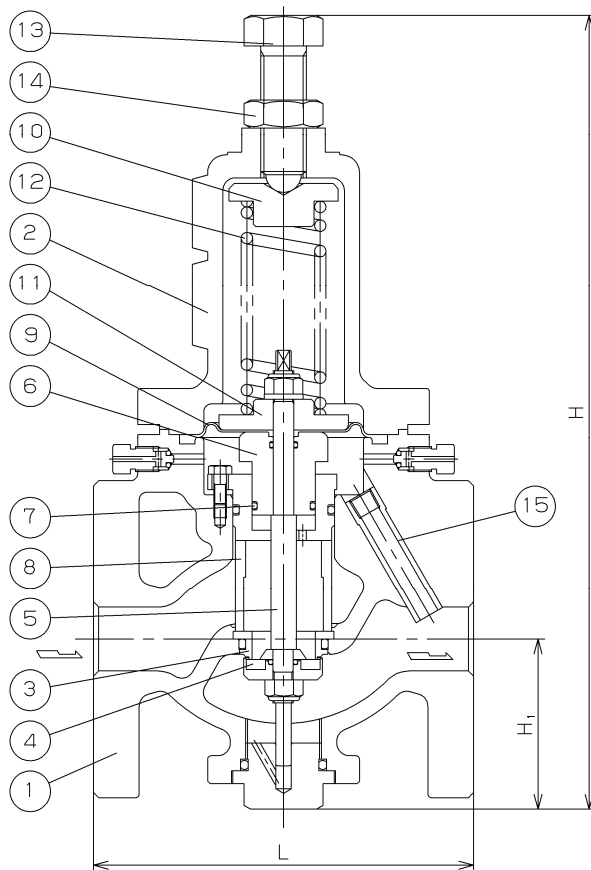

No.	Parts Name
1	Body
2	Spring Chamber
3	Valve Seat
4	Valve
5	Spindle
6	Retainer
7	O Ring
8	Retainer Guide
9	Diaphragm
10	Spring Plate
11	Spring Plate
12	Adjusting Spring
13	Adjusting Screw
14	Lock Nut
15	Conductor Pipe

\*The parts shape differs according to the nominal size.

(mm)

Size	Stainless steel for wetted parts			All stainless steel			Weight (kg)
	L	H	H <sub>1</sub>	L	H	H <sub>1</sub>	
15A	145	310	57	145	297	57	8.2
20A	150	310	57	150	297	57	8.2
25A	150	333	67	150	320	67	10.0
32A	195	397	76	195	397	76	17.3
40A	195	397	76	195	397	76	17.3
50A	195	415	81	195	415	81	19.2
65A	270	550	105	270	550	105	40.0
80A	270	577	120	270	577	120	43.7
100A	308	637	135	308	637	135	70.0

#### 4. Operation

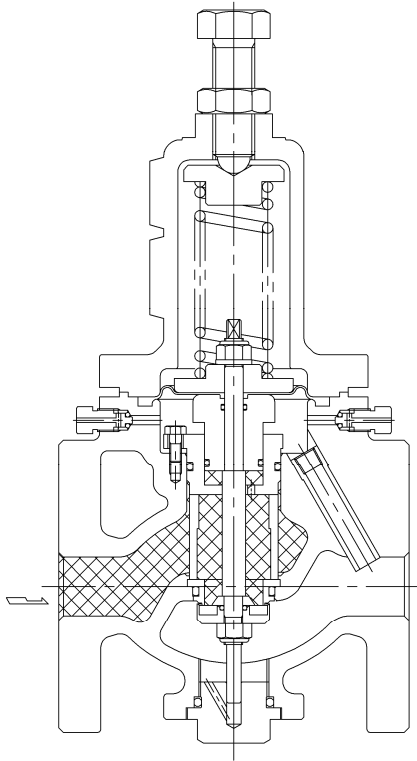

Fig.1

If the adjusting screw<sup>⑬</sup> is turned right, the diaphragm<sup>⑨</sup> will be depressed with an adjusting spring<sup>⑫</sup> and valve<sup>④</sup> connected with spindle<sup>⑤</sup> will open.

The fluid which flowed in from the inlet side carries out the action which pushes up diaphragm through a conductor pipe<sup>⑮</sup> at the same time it flows into an outlet side through the valve upper part.

When the stop valve at the outlet side is closed, the load which pushes up diaphragm increases, the load of an adjusting spring is overcome, and valve is closed.

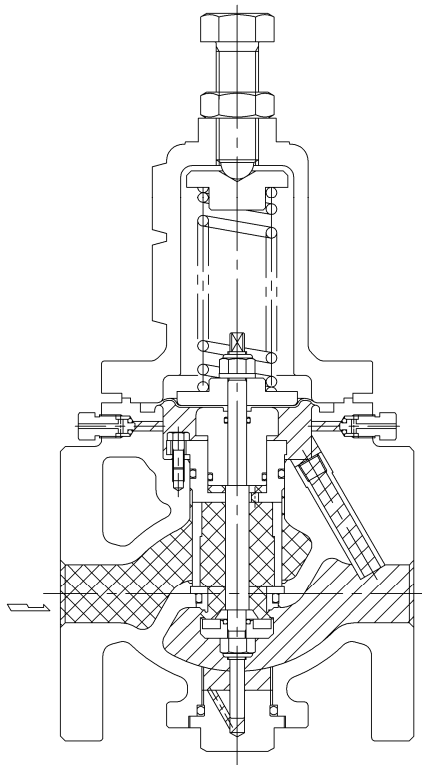

Fig.2

If the stop valve at the outlet side is opened gradually, the load which pushes up diaphragm<sup>⑨</sup> will decrease, the load of an adjusting spring<sup>⑫</sup> will overcome, valve<sup>④</sup> will be opened, and fluid will flow into an outlet side.

The fluid which flowed into the outlet side through a conductor pipe<sup>⑮</sup> carries out the action which pushes up diaphragm, maintains the balance with an adjusting spring load, adjusts the valve opening, and keeps outlet side pressure constant.

5. Nominal Size Selection Method  
 5.1 Nominal Size Selection Chart

< For Water >

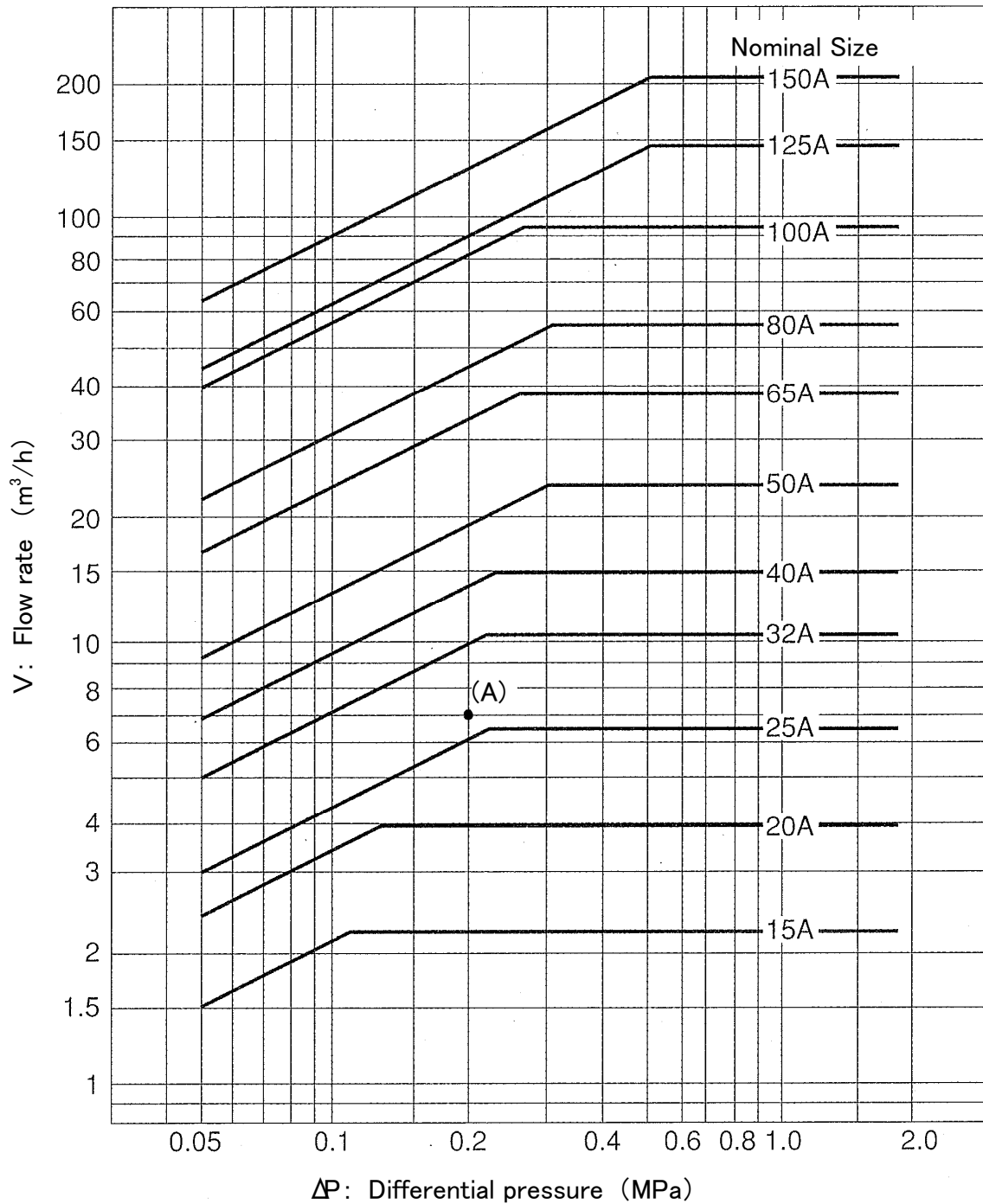

Example of Selection

When the inlet pressure ( $P_1$ ) is 0.5 MPa, the reduced pressure ( $P_2$ ) is 0.3 MPa and the flow rate is 7 m<sup>3</sup>/h, for instance, the size of the pressure reducing valve is selected as follows. Find the intersection point (A) of the differential pressure of 0.2 MPa with the flow rate of 7 m<sup>3</sup>/h, the point (A) is between line of size 25A and 32A. Choose larger size 32A for application.

< For Air >

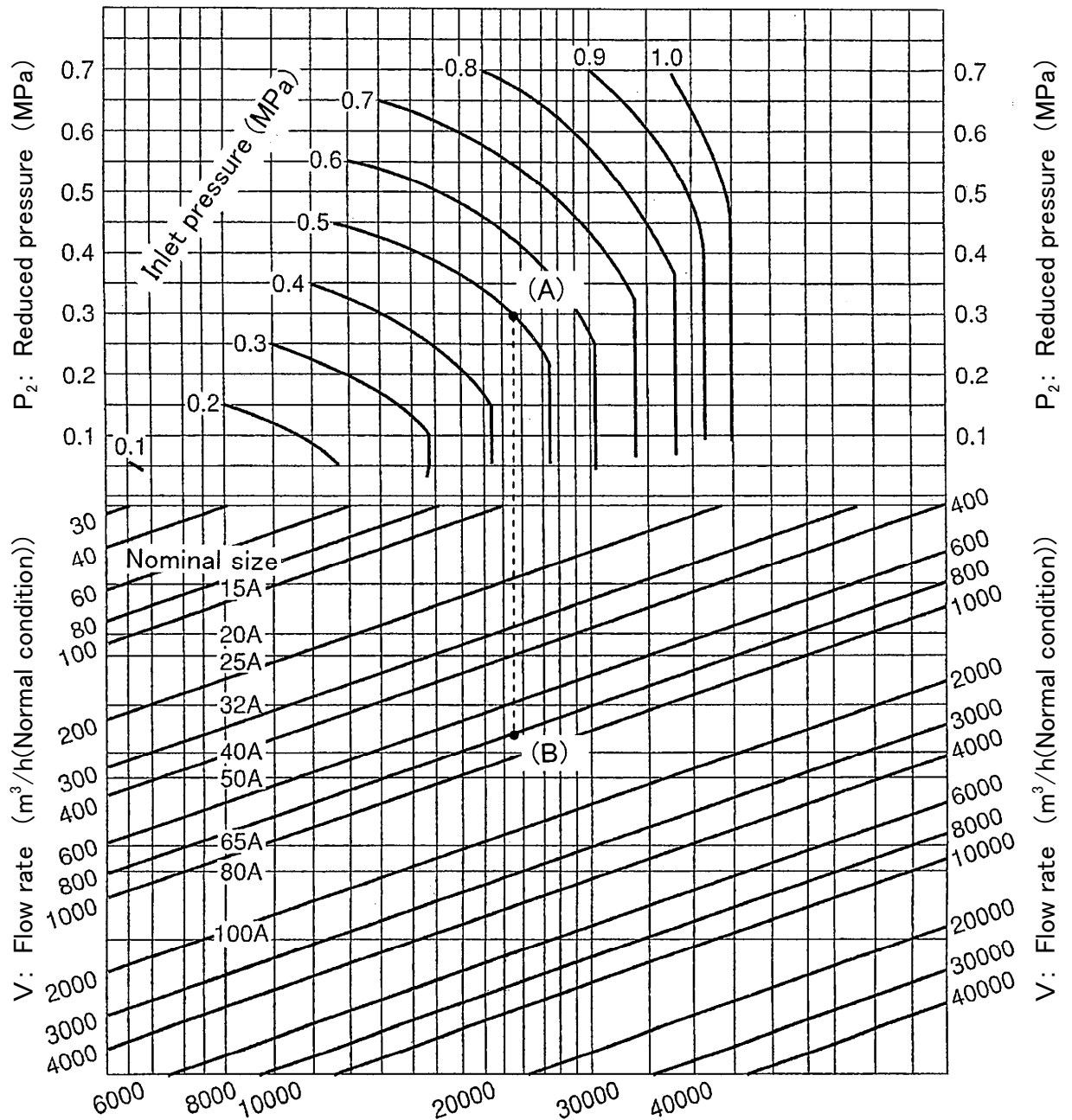

#### Example of Selection

When the inlet pressure ( $P_1$ ) is 0.5 MPa, the reduced pressure ( $P_2$ ) is 0.3 MPa and the flow rate is 800  $m^3/h$ (Normal condition), for instance, the size of the pressure reducing valve is selected as follows.

Find the intersection point (A) of the inlet pressure ( $P_1$ ) 0.5 MPa and reduced pressure ( $P_2$ ) 0.3 MPa and go straight down from the point (A) to find the intersection (B) crossing the flow rate line.

The point (B) is between line of 32A and 40A, and choose larger size 40A for application.

## 5.2 Selection Formula for Nominal Size

• Cv value

Nominal Size	15A	20A	25A	32A	40A	50A	65A	80A	100A
Cv value	2.5	4	5	8	12	16	28	36	68

• Cv Value Calculation Formula

< For Gas >  
In case of  $P_2 > \frac{P_1}{2}$

$$C_v = \frac{Q}{2940} \sqrt{\frac{(273+t)G}{\Delta P (P_1 + P_2)}}$$

In case of  $P_2 \leq \frac{P_1}{2}$

$$C_v = \frac{Q \sqrt{(273+t)G}}{2550P_1}$$

< For Liquid >

$$C_v = \frac{0.365V\sqrt{G}}{\sqrt{\Delta P}}$$

• Viscosity correction Formula

Find the Max. Flow rate (V) when the viscosity is ignored.

$$V = \frac{C_v \sqrt{\Delta P}}{0.365 \sqrt{G}}$$

And find the viscosity index of Iv.

$$I_v = \frac{72780}{Mcst} \left( \frac{\Delta P}{G} \right)^{\frac{1}{4}} V^{\frac{1}{2}}$$

Find the value of K from the value of Iv, found through the above formula, with the viscosity correction curve. The calculated Max. flow rate divided by the value of K is the corrected value.

Compensated Max. flow rate  $V' = V / K$  (m<sup>3</sup>/h)

Viscosity Correction Curve

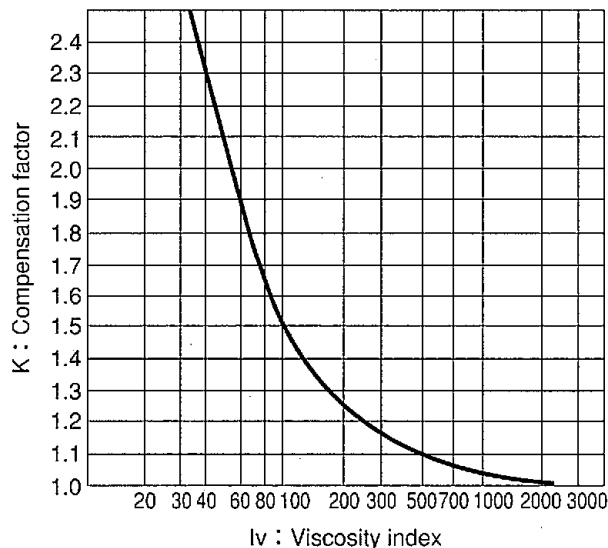

$P_1$  : Inlet pressure [MPa·A]

$P_2$  : Reduced pressure [MPa·A]

$\Delta P$  :  $P_1 - P_2$  [MPa]

G : Specific gravity

(Gas : Specific gravity relative to air)

(Liquid : Specific gravity relative to water)

V : Max. liquid flow rate [m<sup>3</sup>/h]

Q : Max. gas flow rate [m<sup>3</sup>/h(Normal condition)]

T : Temperature [°C]

$C_v$  : Cv value of the nominal size

$I_v$  : Viscosity index

Mcst : Viscosity [cSt]



## 6. Installation

### 6.1 Precautions before operation

#### ⚠Caution

- (1) Since it is weight thing, this product should use lifting equipment etc., and please support a product certainly and install it in piping.  
\*There is a possibility that it may be injured, by fall of product.
- (2) Do not disassemble the valve unreasonably.  
\*Disassembling the valve at your discretion may affect the original performance.
- (3) Remove foreign matter and scales from the lines before connecting the valve.  
\*Failure to do so may prevent the valve from functioning correctly.
- (4) Install a strainer at the valve inlet side.  
\*Failure to do so may hamper correct pressure control, which affects the original performance.
- (5) Install a safety relief valve at the valve outlet sides for alarms.  
\*Failure to do so prevents problem identification, resulting in equipment damage.
- (6) Install a pressure gauge at both the inlet and outlet sides of the valve.  
\*Failure to do so may hamper correct pressure adjustment.
- (7) For gas application, install a trap to the inlet sides of the valve to prevent drainage problem.  
\*Failure to do so may result in drainage problem, affecting the original performance.
- (8) When installing quick open and close valves, such as a solenoid valve, secure at least 3 m from the valve.  
\*Failure to do so may result in malfunction or drastically shortened service life.
- (9) When pressure reducing in two stages, secure at least 3 m between the valves.  
\*Failure to do so may result in malfunction, affecting the original performance.
- (10) Install the valve in proper direction of the fluid flow.  
\*Failure to do so may affect the original performance.
- (11) Do not apply excessive load, torque or vibration to the valve.  
\*Doing so may result in malfunction or drastically shortened service life.

- (1) Pipes can be installed either horizontally or vertically except the size of 100A.
- (2) Set pressure of safety relief valve should be a little higher than the pressure reducing valve's pressure.
- (3) If the large valve is used for gas, install a reducer to prevent excessive flow speed.  
(The flow speed made in piping is appropriate, if it is 15m/s or less.)
- (4) Above the center of the pipe line, be sure to reserve enough space larger than H<sub>2</sub> (Fig.3). Please see the following table.

(mm)									
Nominal Size	15A	20A	25A	32A	40A	50A	65A	80A	100A
H <sub>2</sub>	500	500	500	650	650	650	800	800	1000

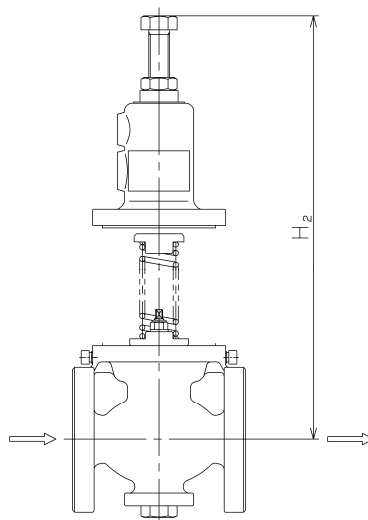
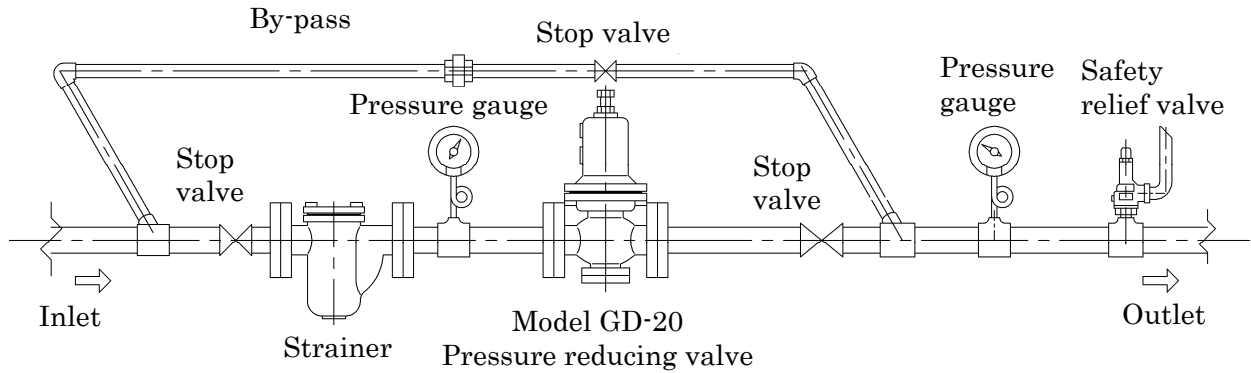

Fig.3

## 6.2 Example of Piping



## 7. Operating Procedure

### 7.1 Precautions for pressure reducing valve operation

#### ⚠Warning

- (1) By sunshine or atmosphere temperature rise, the fluid in piping carries out volume expansion, failure of a reducing valve and the external leak of fluid occur, and there is danger of circumference contamination.  
\*Safety relief valve should be installed at outlet side of reducing valve.
- (2) Do not touch the valve directly with bare hands.  
\*Doing so may result in burns.

#### ⚠Caution

- (1) Close the stop valves before and after the pressure reducing valve, and remove all foreign matter and scales via the by-pass line before operation.  
\*Failure to do so may prevent the valve from functioning correctly.
- (2) When the adjust pressure, slowly turn the adjusting screw.  
\*Incorrect adjustment may cause hunting, water hammer, etc., resulting in damage to the valve and other equipment.
- (3) Remove condensate completely from the line, and close the stop valves before and after the valve when not using it for long periods of times.  
\*Rust generated in the valves and lines may cause malfunction.

## 7.2 Adjustment Procedure

### ⚠ Caution

(1) Follow the steps below, and slowly turn the adjusting screw to set pressure. Incorrect adjustment may cause hunting, water hammer, etc., resulting in damage to the valve and other equipment.

- (1) Close the stop valves at both sides of the pressure reducing valve, and thoroughly purge the system through the by-pass line, with the by-pass valve opening adjusted so that the safety relief valve is not activated. When completed, be sure to close the by-pass valve.
- (2) Slowly open the inlet stop valve, then open the outlet stop valve slightly, allowing a trickle to be discharged.
- (3) Loosen the lock nut<sup>⑭</sup>, and slowly turn the adjusting screw<sup>⑬</sup> (clockwise to increase, counterclockwise to reduce) while observing the pressure gauge on the outlet side.
- (4) Slowly open the outlet stop valve to its full-open position.
- (5) After the adjustment, tighten the lock nut.
- (6) In case of secondary pressure for size 65A to 100A is unstable because of an air obstruction or etc., adjust opening of needle valve at detecting pipe.

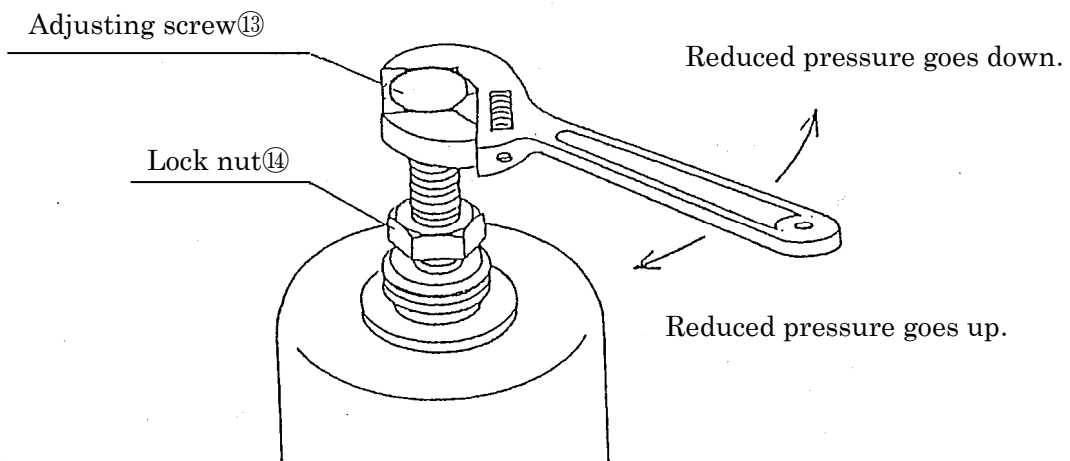

8. Maintenance Procedure  
8.1 Troubleshooting

Problem	Causes	Solutions
Pressure does not rise to desired level.	<ol style="list-style-type: none"> <li>1. Incorrect pressure is being used.</li> <li>2. The conductor pipe<sup>⑤</sup> is clogged with foreign matter.</li> <li>3. Nominal size is too small for these specifications.</li> <li>4. Incorrect adjustment.</li> <li>5. Strainer is clogged.</li> <li>6. Pressure gauge malfunction.</li> </ol>	<ol style="list-style-type: none"> <li>1. Correct the pressure being used. (Refer to the "Specifications".)</li> <li>2. Disassemble and clean the conductor pipe.</li> <li>3. Replace with the correct nominal sized item.</li> <li>4. Re-adjust according to the adjustment procedure. (Refer to the "Adjustment Procedure".)</li> <li>5. Disassemble and clean.</li> <li>6. Replace the pressure gauge.</li> </ol>
Reduced pressure exceeds prescribed level.	<ol style="list-style-type: none"> <li>1. Foreign matter is embedded in the valve<sup>④</sup> and/or valve seat<sup>③</sup>, or else scratches exist.</li> <li>2. O-ring<sup>⑦</sup> is broken.</li> <li>3. By-pass valve is leaking.</li> </ol>	<ol style="list-style-type: none"> <li>1. Disassemble and clean. If scratches exist, replace them.</li> <li>2. Replace the O-ring.</li> <li>3. Repair or replace the valve.</li> </ol>
Abnormal noise is heard.	<ol style="list-style-type: none"> <li>1. Nominal size is too large for these specifications.</li> <li>2. Pressure reduction ratio is too large.</li> <li>3. Air problem is caused. (Liquid use)</li> <li>4. An abrupt OPEN/CLOSE valve is located too close to the pressure reducing valve.</li> </ol>	<ol style="list-style-type: none"> <li>1. Replace with the correct nominal sized item.</li> <li>2. Use a two-stage reduction. (Refer to the "Specifications".)</li> <li>3. Install a trap.</li> <li>4. Allow as much distance as possible between the valves.</li> </ol>

\*Foreign matter and scales in pipe may cause most of problems of pressure reducing valve. Be careful sufficiently to foreign matter in pipe.

\*Phenomenon alike valve trouble may happen by fault of pressure gauge, fluid leakage from by-pass valve, forgetting to close the by-pass valve, clogging strainer, and etc. First, check the said particulars before above troubleshooting.

8.2 Precautions during disassembly and inspection

**△Warning**

The pressure reducing valve shall be disassembled and inspected by qualified persons.  
 (1) Completely discharge internal pressure from the valves, lines, and equipment, and cool the valve down to a level where you can touch it with bare hands before disassembly and inspection.  
 \*Failure to do so may result in injury or burns due to residual pressure or spillage around the valve.

### 8.3 Disassembly

- (1) Release the internal pressure completely, and make sure of zero pressure.
- (2) Slightly loosen the lock nut<sup>⑭</sup> and turn the adjusting screw<sup>⑬</sup> counter clockwise to relieve the adjusting spring<sup>⑫</sup> (Unload the spring).
- (3) Remove the hexagon bolt from the spring chamber<sup>②</sup>, then remove the spring chamber, and take out the adjusting spring and the spring plate<sup>⑩</sup>.
- (4) To remove the diaphragm<sup>⑨</sup>, fix the spindle<sup>⑤</sup> and remove the U nut.
- (5) To remove the retainer<sup>⑥</sup>, loosen and remove the retainer guide clamping bolt and pull the retainer guide<sup>⑧</sup>.
- (6) To remove the valve seat<sup>③</sup>, pull the spindle. Remove it by the bellow method (Fig.4, Fig.5) when it is difficult to remove the retainer guide.

#### Nominal Size 15~50A

To remove the retainer guide<sup>⑧</sup> easily, install the spring plate<sup>⑪</sup> and U nut to spindle<sup>⑤</sup> again and pull the spring plate. (Fig.4)

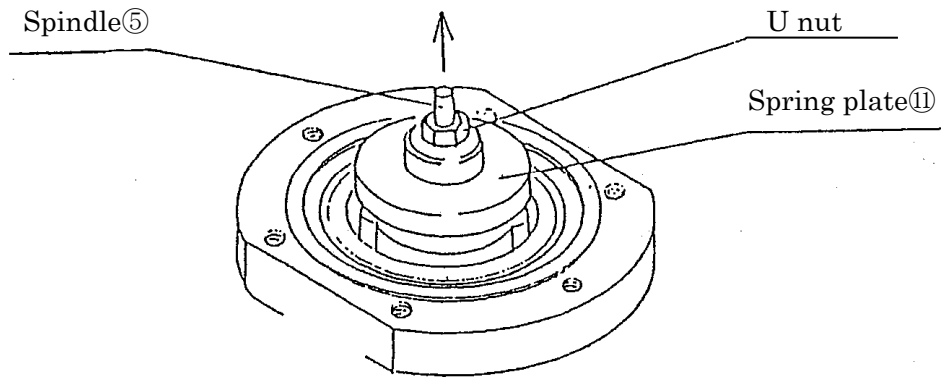

Fig.4

#### Nominal Size 65~100A

To remove the retainer guide<sup>⑧</sup> easily, screw the retainer guide clamping bolt to retainer guide and pull it. (Fig.5)

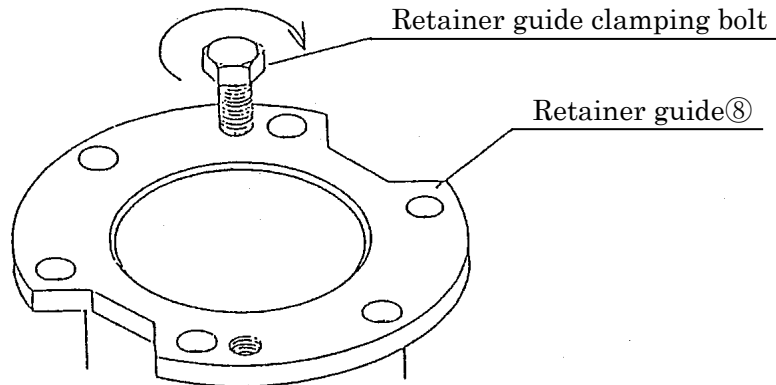
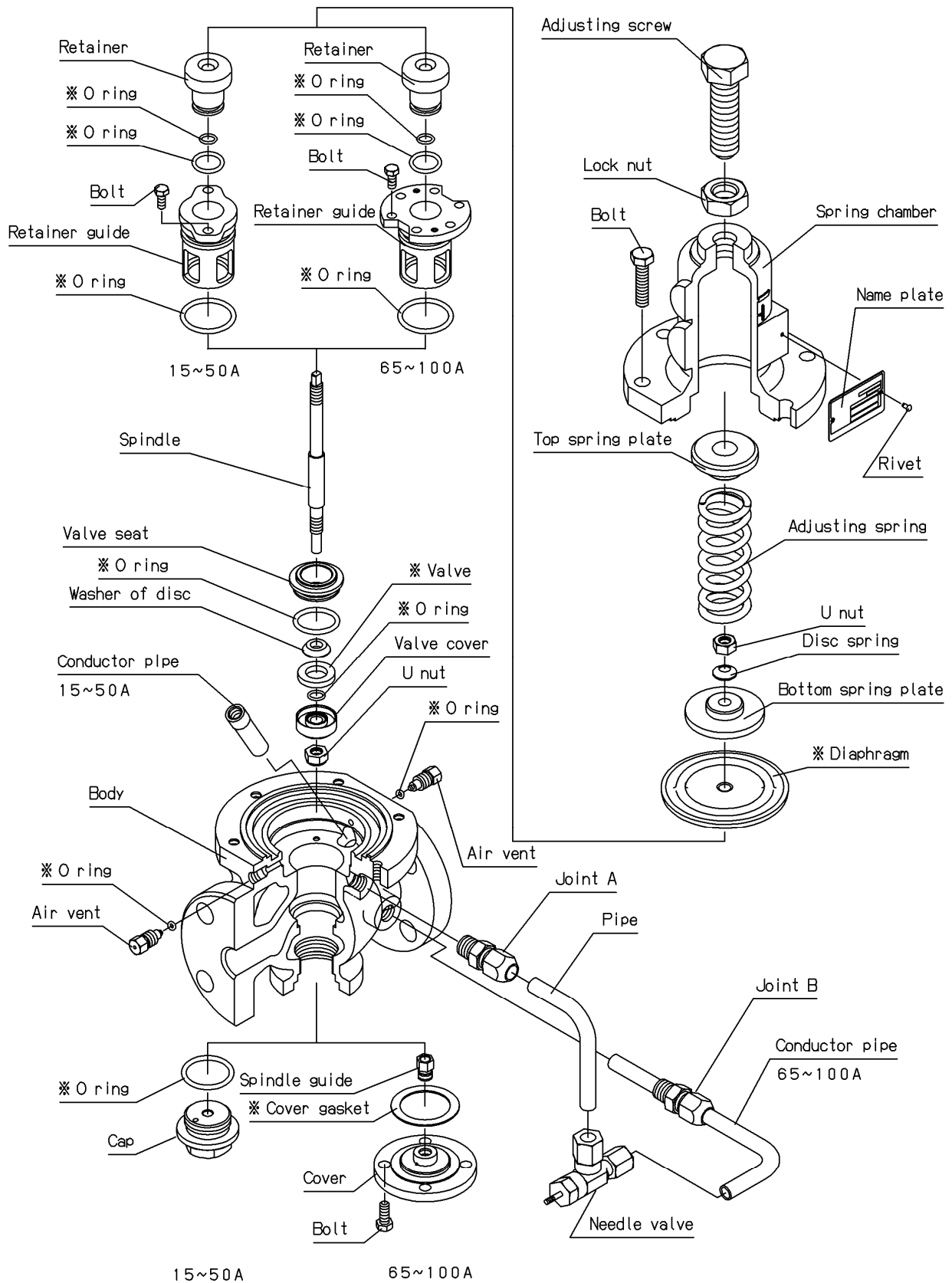

Fig.5

### 8.4 Precautions during disassembly

- (1) Make sure that the diaphragm<sup>⑨</sup>, the valve seat<sup>③</sup>, and the valve<sup>④</sup> have no scratches.
- (2) Apply the silicon grease to the O-Ring<sup>⑦</sup> after confirm whether there are any flaw on the O-Ring.
- (3) Install the spring chamber<sup>②</sup> after the confirm whether the border of diaphragm is fitted with the groove of body<sup>①</sup>.
- (4) There is a gap between retainer guide<sup>⑧</sup> and body shows these parts positioned correctly. Tighten the bolts evenly and be sure to tight too hard.

## 8.5 Exploded drawing



• Parts with the ※ are consumable.  
Please contact us for purchase of these consumable parts.