

8	Rivet	Carbon Steel	打込みねじ	S15C	2
7	Name Plate	Stainless Steel	銘板	SUS304	1
6	Plug	Carbon Steel	プラグ	S45C	1
5	Bolt	Carbon Steel	六角穴付ボルト	SCM435	1set
4	Gasket	Non Asbestos	ガスケット	Non Asbestos	1
3	Nozzle	Cast Iron	ノズル	FC200	1
2	Receiver	Ductile Cast Iron	レシーバー	FCD450	1
1	Body	Ductile Cast Iron	本体	FCD450	1
No.	Name of Parts	Material	部品名	材質	Q.TY

Size	L	H ₁	H	d ₀	Flange JIS 10K FF				Weight (kg)
					D	C	t	n-h	
15A	174	193	243	Rc 3/4	95	70	12	4-15	8.5
20A	204	193	243	Rc 3/4	100	75	14	4-15	9.6
25A	204	193	243	Rc 3/4	125	90	14	4-19	10.1
32A	222	213	282	Rc 1	135	100	16	4-19	15.6
40A	242	213	282	Rc 1	140	105	16	4-19	16.3
50A	246	260	342	Rc 1	155	120	16	4-19	24.7
65A	288	314	418	Rc 1	175	140	18	4-19	40.0
80A	335	361	484	Rc 1 1/4	185	150	18	8-19	54.0
100A	390	445	594	Rc 1 1/4	210	175	18	8-19	96.0

Specification	
Fluid	
Press.	MPa
Temp.	

TYPE DS-2 DRAIN SEPARATOR ドレンセパレーター

Approval	T. Nishiyama
Check	T. Shinjo
Drawing	T. Nagasaka
Drawing No.	Y-737-6505
Date	10 MAR. 2009



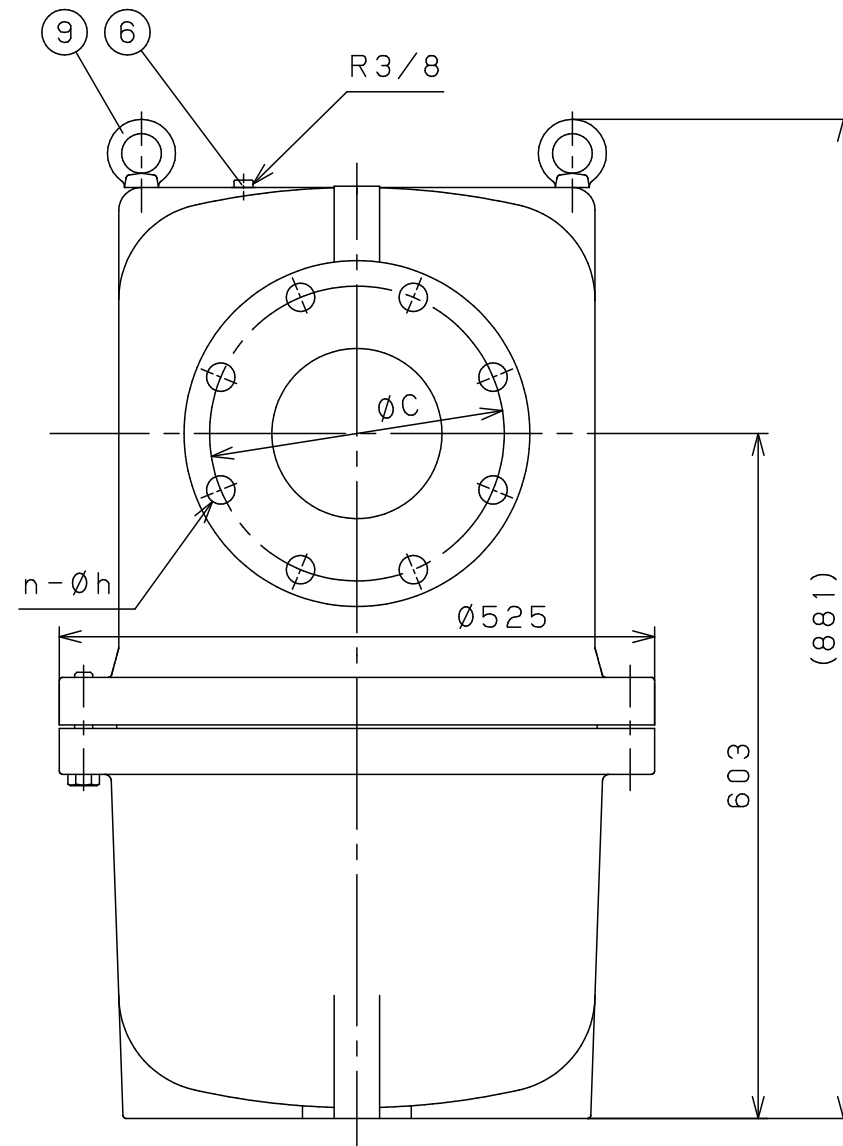
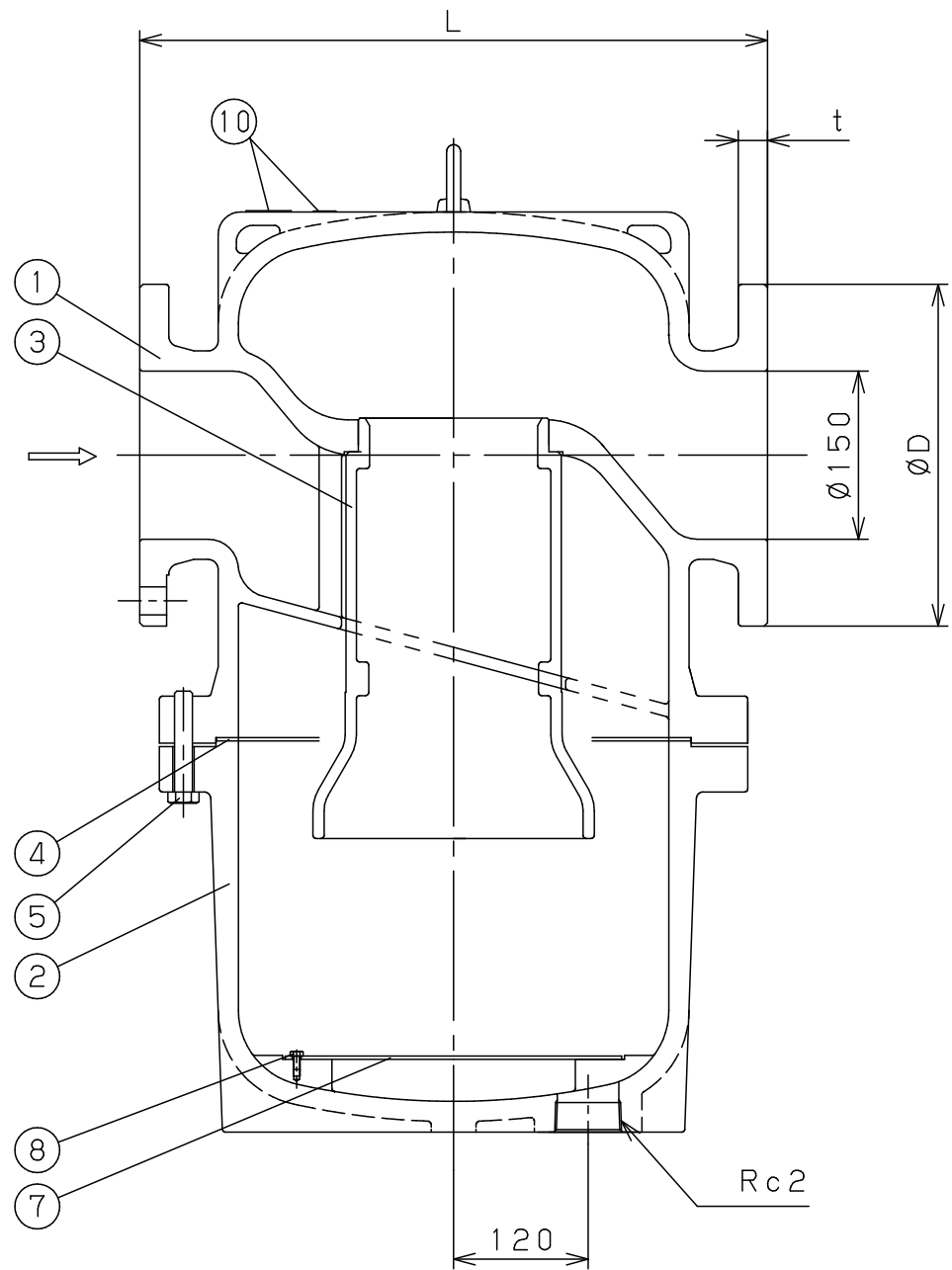

Caution

This drawing may contain information like the covert intelligence etc. legally defended. Disclosing the content of this drawing and information etc. for the production of trial product and mass-produced goods or to the third party are prohibited. Yoshitake inc.

注意

当図面には、秘密情報など法的に守られた情報を含んでいる場合があります。当図面を用いての試作・量産品の製作、並びに第三者への内容・情報の開示等を禁止します。株式会社 ヨシタケ

Specification	
Fluid	
Press.	MPa
Temp.	℃

※第二種圧力容器受検品です。

(mm)

Size	L	Flange JIS 10K FF				Weight (kg)
		D	C	t	n-h	
150A	556	280	240	22	8-23	280

(乾燥重量)

※フランジ厚みと外径は上記より大きくなる場合があります。

10	Name Plate	Stainless Steel	銘版	SUS304	2
9	Eye Bolt	Steel	アイボルト	Steel	2
8	Bolt	Stainless Steel	六角ボルト	SUS	2
7	Baffle Plate	Stainless Steel	バッフルプレート	SUS304	1
6	Plug	Steel	プラグ	Steel	1
5	Bolt	Steel	六角ボルト	Steel	18
4	Gasket	Non Asbestos	ガスケット	Non Asbestos	1
3	Nozzle	Cast Iron	ノズル	FC200	1
2	Receiver	Ductile Cast Iron	レシーバー	FCD450	1
1	Body	Ductile Cast Iron	本体	FCD450	1
No.	Name of Parts	Material	部品名	材質	Q. TY

TYPE DS-2 DRAIN SEPARATOR
ドレンセパレーター

Approval	H. Iwamoto
Check	H. Kamada
Drawing	S. Suzuki
Drawing No.	Y-737-6505-2C
Date	10 DEC.2019

