

MODEL AL-27 SAFETY RELIEF VALVE

PRODUCT MANUAL

Thank you very much for choosing the Yoshitake's product. To ensure the correct and safe use of the product, please read this manual before use. This manual shall be kept with care for future references. The symbols used in this manual have the following meanings.



	Warning	This symbol indicates a potentially hazardous situation that, if not avoided, could result in death or serious injury.
	Caution	This symbol indicates a hazardous situation that, if not avoided, may result in minor or moderate injury or may result in only property damage.

Table of Contents

1. Usage of the Product	1
2. Specifications	1
3. Dimensions and Weight	2
4. Structure	3
5. Operation	3
6. Nominal Size Selection Chart	4
7. Installation	7-12
7.1 Fitting pipe base	8
7.2 Discharge pipe	8
7.3 Set pressure adjustment	9-12
8. Maintenance	12
8.1 Daily inspection	12
8.2 Periodic inspection	12
8.3 Troubleshooting	13-14
Warranty Information	

YOSHITAKE

1. Usage of the Product

The AL-27 is a relief valve for pressure control in a pump system in which large pressure pulsation or fluctuation occurs.

2. Specifications

Model	AL-27	
Structure	Closed type	
Application	Cold and hot water, Oil (heavy oil A, heavy oil B, kerosene), other non-dangerous fluids (20 cSt or less)	
Working pressure	0.05 - 1.6 MPa	
Max. temperature	120°C	
Connection	JIS Rc screwed	
Nominal size	15-50A	
Material	Spring case	Ductile cast iron
	Valve, valve seat	Stainless steel



Warning

1. Do not apply the product to equipment or devices which do not allow any valve seat leakage.
* The product has allowable valve seat leakage and does not close completely (valve seat leakage cannot be zero).
2. Do not use the product for equipment or device which vibrates excessively.
* Failure to follow this notice may result in malfunction.



Caution

Please confirm that the indications on the product correspond with the specifications of the ordered product model before use.
* If they are different, do not use the product and contact us.

3. Dimensions and Weight

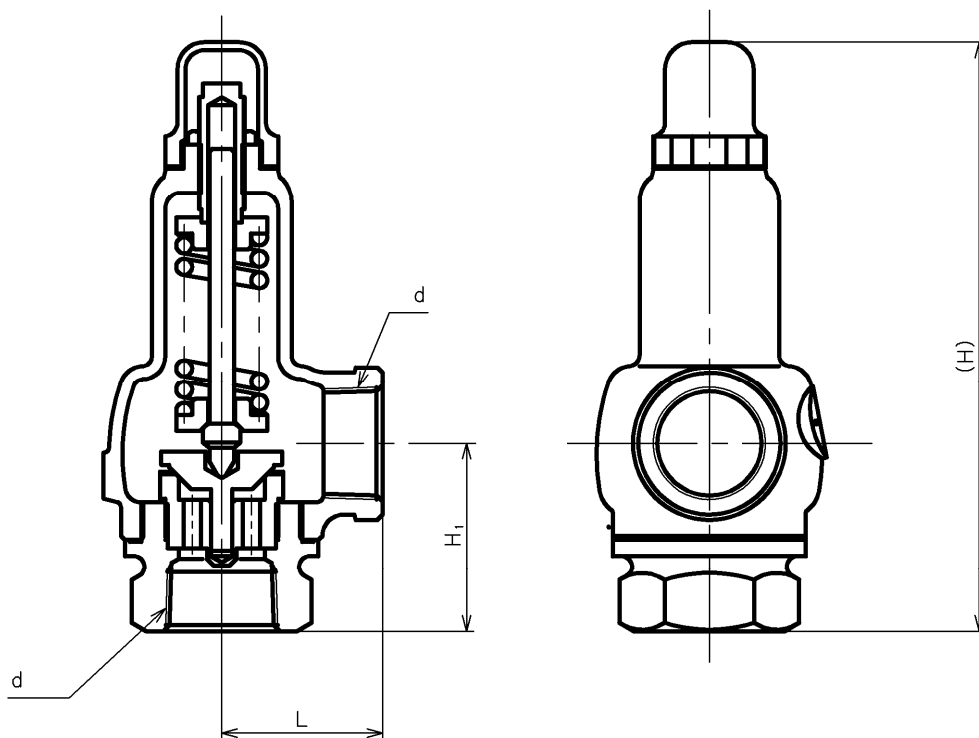

Figure 1. Dimensions

Table 1. Dimensions and weight

Nominal Size	(mm)				
	d	L	H ₁	H	Weight(kg)
15A	Rc 1/2	40	40	143	0.9
20A	Rc 3/4	45	50	162	1.3
25A	Rc 1	50	60	182	1.7
32A	Rc 1 1/4	60	70	220	2.9
40A	Rc 1 1/2	65	75	238	3.9
50A	Rc 2	80	85	272	6.4

4. Structure

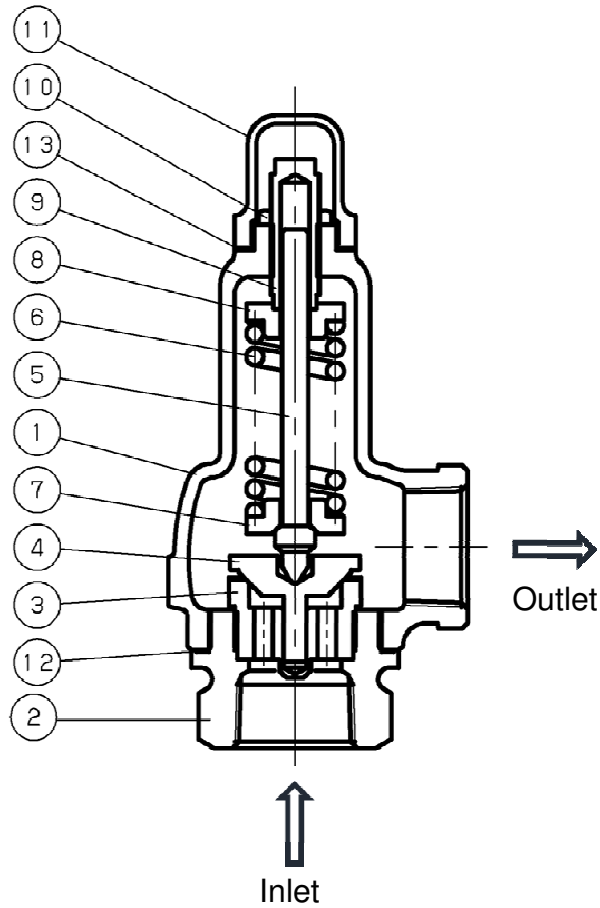

Figure 2. Structure

Table 2. Parts list

7	Spring plate		
6	Spring	13	Gasket
5	Spindle	12	Gasket
4	Valve	11	Cap
3	Valve seat	10	Lock nut
2	Body	9	Adjusting screw
1	Spring case	8	Spring plate
Nº	Part name	Nº	Part name

5. Operation

As the inlet pressure approaches the set pressure, the force of fluid pushing up the valve [4] approaches the force of the spring [6] pressing down the valve [4]. When the inlet pressure increases further, the valve [4] opens and discharges the fluid. The valve lift changes responding to the inlet pressure and controls it. (See Figure 2.)

6. Nominal Size Selection Chart

The flow rate of each size with 25% of accumulation (excess to the set pressure) is shown in Figure 3. See Figure 4 when the accumulation is less than 25%.

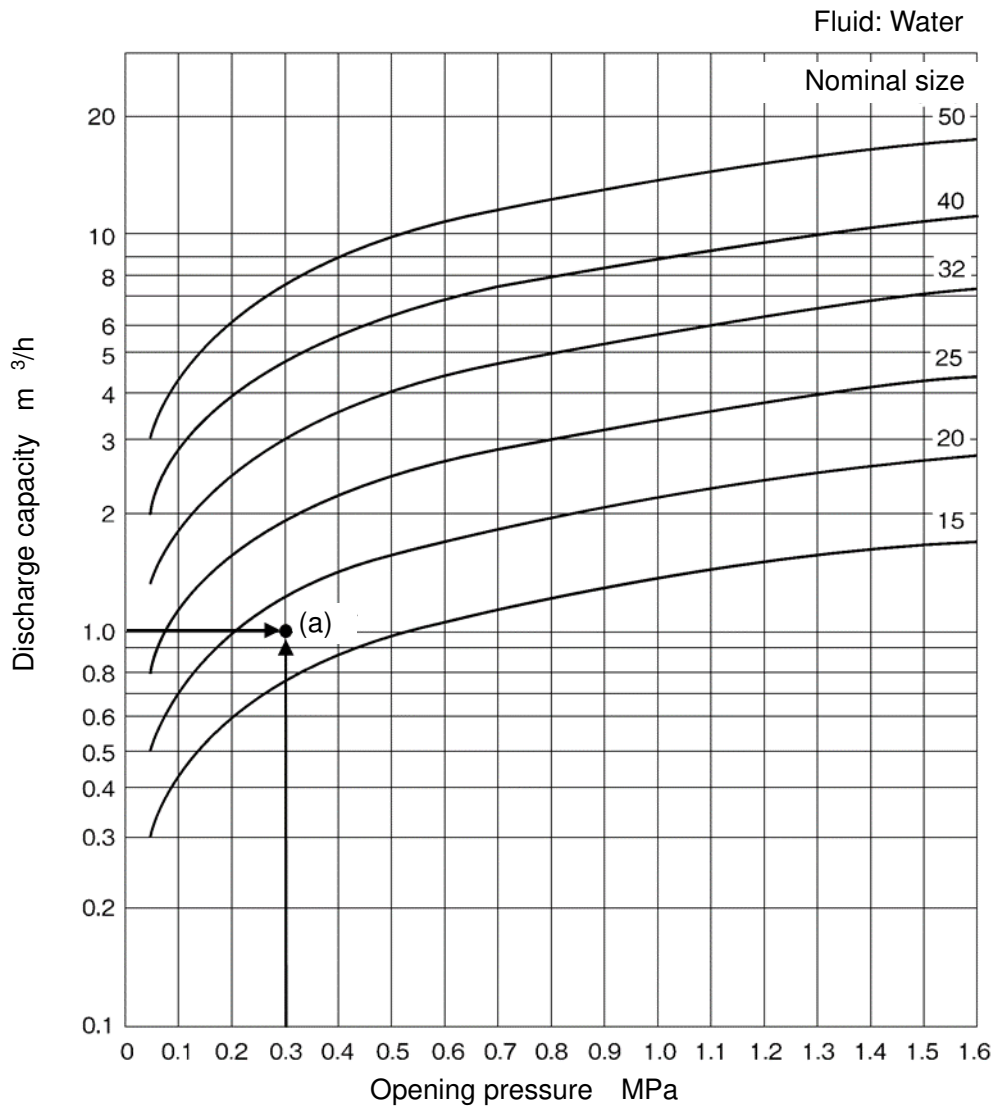

Figure 3. Nominal size selection chart

Example:

When selecting the nominal size for opening pressure of 0.3 MPa and discharge capacity of 1.0 m³/h, find the intersection point (a) of the opening pressure of 0.3 MPa and the discharge capacity of 1.0 m³/h. The intersection point (a) lies between the nominal sizes 15A and 20A, select the larger one, 20A.

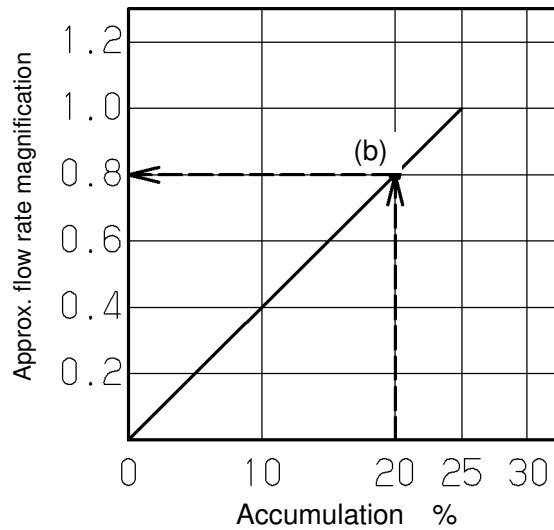

Figure 4. Approximate flow rate magnification

Figure 4 is referred to when calculating the approximate flow rate with accumulation less than 25%.

Example:

When calculating the flow rate of the size of 25A, with the opening pressure of 0.1 MPa, and accumulation of 20%, first, find the flow rate with the accumulation of 25% by using Figure 3. Next, find the intersection (b) with the accumulation of 20% by Figure 4 and read the value of the approx. flow rate magnification, that is 0.8. Multiple the opening pressure found in Figure 3 by the approximate flow rate magnification found in Figure 4.

$$1.08(\text{m}^3/\text{h}) \times 0.8(\text{magnification}) \doteq 0.86(\text{m}^3/\text{h})$$

Thus, the flow rate with the accumulation of 20% is approximately 0.86 m³/h.

Table 3 shows discharge capacities at certain pressures for reference.

Table 3. Discharge capacity (for Reference)

[Accumulation: 25%]

(m³/h)

Nominal size	Set pressure (MPa)										
	0.05	0.1	0.2	0.3	0.4	0.5	0.6	0.7	0.8	0.9	1.0
15A	0.30	0.42	0.6	0.74	0.85	0.95	1.04	1.13	1.21	1.28	1.35
20A	0.49	0.69	0.98	1.20	1.39	1.55	1.70	1.84	1.96	2.08	2.20
25A	0.77	1.08	1.54	1.88	2.17	2.43	2.66	2.88	3.08	3.26	3.44
32A	1.26	1.78	2.52	3.09	3.57	3.99	4.37	4.72	5.04	5.35	5.64
40A	1.98	2.80	3.96	4.85	5.60	6.26	6.86	7.41	7.92	8.40	8.86
50A	3.09	4.37	6.18	7.57	8.74	9.77	10.71	11.57	12.37	13.12	13.83

(m³/h)

Nominal size	Set pressure (MPa)					
	1.1	1.2	1.3	1.4	1.5	1.6
15A	1.42	1.48	1.54	1.6	1.65	1.71
20A	2.30	2.41	2.51	2.60	2.69	2.78
25A	3.61	3.77	3.92	4.07	4.21	4.35
32A	5.92	6.18	6.43	6.67	6.91	7.14
40A	9.29	9.70	10.10	10.48	10.85	11.21
50A	14.50	15.15	15.76	16.36	16.93	17.49

7. Installation



Warning

1. Do not install any closing devices such as a stop valve at inlet or outlet side of the product.
2. Do not apply the product to equipment or devices which do not allow any valve seat leakage.
3. Install an exhaust pipe on outlet side of the product, and lead it to a place where there is no risk of physical damage even if fluid blows out.
* Failure to follow this notice may result in injury and scalds in case of fluid blow out.
4. Do not disassemble the product.
* Failure to follow this notice may prevent the product from functioning properly and lead to danger.
5. Securely connect the product with the piping
* Failure to follow this notice may cause fluid leakage from the connections due to vibration resulting in injury and scalds.
6. When installing, tighten the hexagonal part of the body with a spanner.
7. Do not apply viscous fluid that may make the valve and valve seat stuck together.
* Failure to follow this notice may cause malfunction due to sticking together of the valve and valve seat.
8. When connecting a pipe to the product outlet, do not adjust the direction of the product by applying force to the pipe.
* Failure to follow this notice may cause blowout due to damage on the thread or loose connection.



Caution

1. When installing the product, match the direction of fluid flow with the inlet and outlet of the product respectively.
* Failure to follow this notice prevents the product from functioning properly and discharging the pressure from the outlet and may result in damage to the device or injury.
2. Before installing the product, remove foreign substances and scale from the piping. Be careful that sealing materials do not contaminate inside of the piping.
* Failure to follow this notice may result in malfunction. Repair due to foreign substances is charged.
3. Install the product vertically with the cap [11] upward. Taking an example with Figure 5, the product must be vertical against water surface in the tank because the surface is horizontal.
* Failure to follow this notice prevents the product from functioning properly and discharging the pressure from the outlet.
4. Securely support and fasten the pipes.
(See "7.1 Fitting pipe base" and "7.2 Discharge pipe.")
* The product may be deformed and does not open or close if excessive stress is applied.
5. Do not apply flow rate with the accumulation of more than 25% to the product, or flow velocity at the outlet side exceeds 2 m/s and causes noise and vibration.
6. Secure enough space around the product for its maintenance and inspection.

7.1 Fitting pipe base (See Figure 5.)

- (1) Fitting pipe base should have enough strength and rigidity against the stress induced by reaction force in the opposite direction of the exhaust through the axis of the exhaust pipe.
- (2) Equip the discharge pipe with a support to avoid excessive load, deflection, or vibration.
- (3) Install the product at a place where its maintenance and inspection can be performed.

7.2 Discharge pipe (See Figure 5.)

Diameter of the discharge pipe should be the same or larger than that of the outlet of the product.

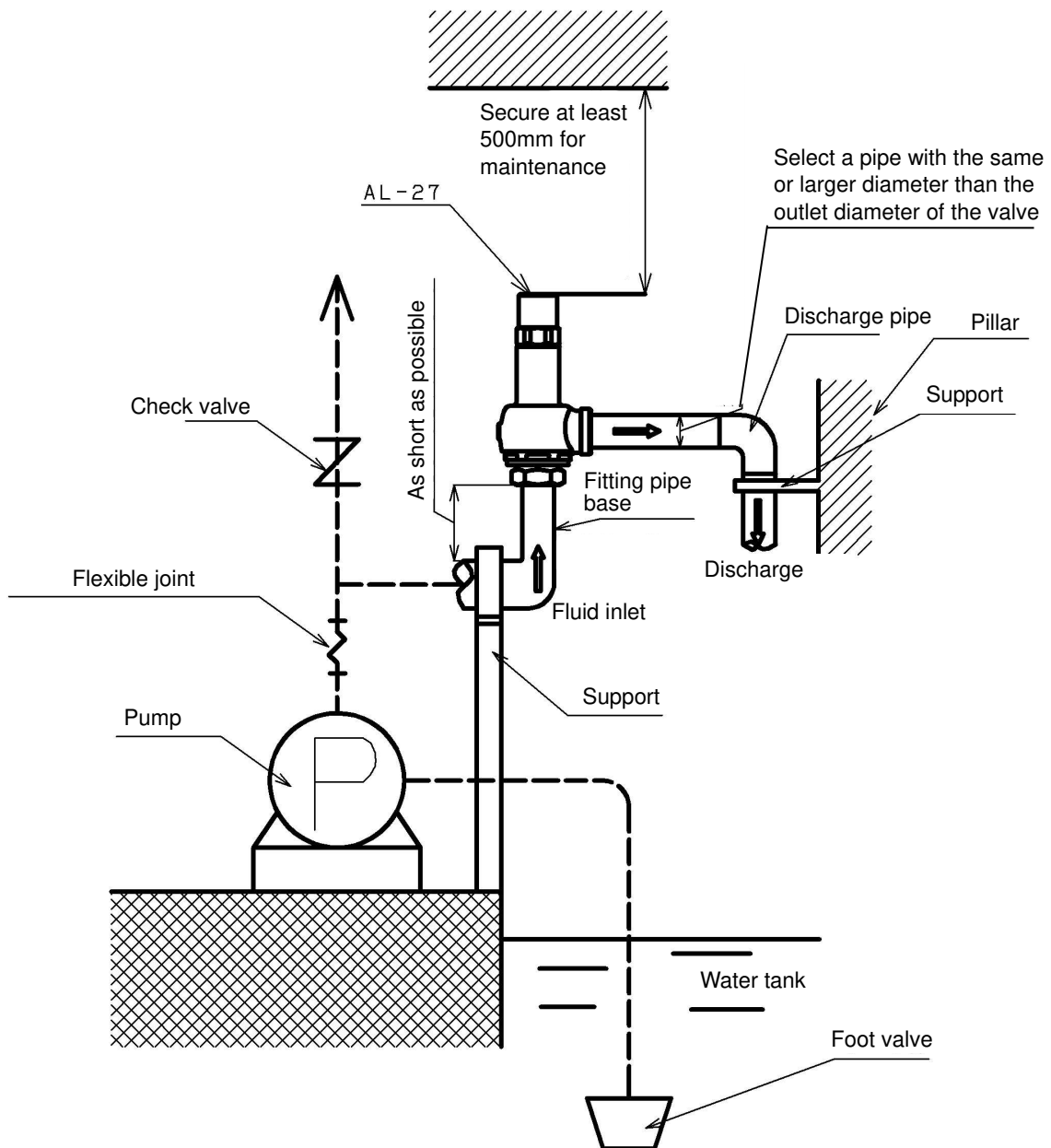

Figure 5. Piping example

7.3 Set pressure adjustment (See 4. Structure)



Warning

To adjust the set pressure, remove the cap [11], make a 1/4 to 1/3 turn of the adjusting screw [9] slowly as checking the pressure gauge, and check the operation each time after turning the adjusting screw [9]. Be careful not to overturn or the fluid may suddenly blow out. The fluid leaks from the thread of the adjusting screw [9] while adjustment. Be careful not to get injured or scalded and not to make the surroundings dirty. When it is difficult to adjust by yourself, please contact us.

* Hot fluid may cause injury and scalds when it blows out.



Caution

Do not try to adjust the set pressure beyond the set pressure range defined per spring. Please refer to Table 4. Set pressure range.

* Failure to follow this notice results in malfunction.

Table 4. Set pressure range

Nominal size	Set pressure range (MPa)				
Spring range	A	B	C	D	E
15-50A	0.05 up to 0.2	Over 0.2 up to 0.4	Over 0.4 up to 0.65	Over 0.65 up to 1.0	Over 1.0 up to 1.6

When a set pressure is not specified, confirm if the set pressure range is proper by checking the alphabet punched on the edge of the screwed connection. (See below.)



Adjustment procedures (See 4. Structure.)

Pictures below show the product only. However, actual adjustment should be done while the product is installed on the piping.



1. AL-27 Safety relief valve



2. Remove the cap [11] with a wrench by turning it counterclockwise.



Warning

The fluid leaks when the cap [11] is removed. Be careful not to get injured or scalded and not to make the surroundings dirty.



3. The lock nut [10] appears after you remove the cap [11]. Loosen the lock nut [10] by turning it counterclockwise with a wrench.



4.1 To decrease the set pressure, make a 1/4 to 1/3 turn of the adjusting screw [9] counterclockwise slowly by a spanner or a wrench. Check the operation of the product after each turn.



4.2 To increase the set pressure, make a 1/4 to 1/3 turn of the adjusting screw [9] clockwise slowly by a spanner or a wrench. Check the operation of the product after each turn.



Warning

The fluid leaks from the adjusting screw [9] while adjustment. Be careful not to get injured or scalded and not to make the surroundings dirty.



5. Fasten the lock nut [10] by turning it clockwise after the adjustment is done.

5. Confirm that there is no damage on the gasket [13] prior to attaching the cap [11]. If the gasket [13] is damaged, it must be replaced with a new one which is recommended to be prepared in advance.

Before attaching the gasket [13], apply paste (Recommendation: SOLVEST No.110, STT Inc.) to its surfaces and its inner diameter surface, and then attach the gasket [13].

Attach the cap [11] and tighten it by turning it clockwise. If outside leakage is observed while relieving operation, retighten the cap [11].



8.Maintenance

Warning

1. Do not touch the product/pipes with bare hands.
* Failure to follow this notice may result in scalds or injury when the fluid is hot.
2. Do not touch the product unless it is necessary.
* Failure to follow this notice may result in scalds or injury when the fluid is hot.
3. When checking the operation of the product, do not stand in front of the exhaust pipe or put your face close to or touch it.
* Failure to follow this notice may result in scalds or injury due to blow-off.
4. Do not disassemble the product.
* Please contact us if any abnormal condition is observed.

Caution

1. When increasing the fluid pressure, check that there will be no problem with the equipment installed in the piping prior to applying higher pressure.
* Failure to follow this notice may damage the equipment.
2. Completely discharge fluid from the product and piping before leaving the product not operated for a long time.
* Failure to follow this notice may cause foreign substances and scale inside of the piping and may result in malfunction of the product.
3. If the product is not operated for a long time, perform inspection before starting operation.

8.1 Daily inspection

Check the following while the system is in operation.

- Corrosion or crack on the product
- Outside leakage from the product
* Please contact us if any abnormal condition is observed.

8.2 Periodic inspection (once per month)

Check that there is no outside leakage from the inlet and outlet connections with the pipes, and also check that the cap [11] is fastened securely.

* Please contact us if any abnormal condition is observed.

8.3 Troubleshooting

Trouble	Cause	Solution
Blows at a pressure lower than the set pressure.	1. Adjusting screw [9] is loosened due to loose lock nut [10] or vibration applied.	1. See "7.3 Set pressure adjustment."
	2. Set pressure does not meet the specifications required.	2. Check the specifications. The product needs to be disassembled and some parts need to be replaced at Yoshitake. Please contact us.
	3. The product malfunctions due to vibration applied.	3. See "2. Specifications" and "7. Installation."
	4. The product is installed in a wrong direction.	4. See "7. Installation."
	5. Pressure gauge is broken.	5. Calibrate or replace the pressure gauge.
	6. The product was damaged while transportation.	6. Please contact us.
Leakage (Except outside leakage)	1. Foreign substance stuck on contact surfaces of the valve [4] and valve seat [3]. Or damage on the surfaces.	1. The product needs to be disassembled and the damaged parts need to be replaced by Yoshitake.
	2. The product malfunctions due to vibration.	2. See "2. Specifications" and "7. Installation."
	3. Fluid pressure reaches or exceeds the start to discharge pressure due to pulsation.	3. See "2. Specifications" and "7. Installation."
	4. Valve seat [3] is loose.	4. The product needs to be disassembled and the damaged parts need to be replaced by Yoshitake.
	5. The product is installed in a wrong direction.	5. See "7. Installation."
	6. The specifications do not meet the requirements from the user.	6. See "2. Specifications" and "7. Installation."
	7. The product was damaged during transportation.	7. Please contact us.
Outside leakage	1. Damage on spring case [1], body [2], cap [11], or gaskets [12] [13] due to abnormal pressure rise, etc.	1. The product needs to be replaced. Check "2. Specifications."
	2. Corrosion of spring case [1], body [2], or cap [11], etc.	2. The product needs to be replaced. Check "2. Specifications."
	3. Cap [11] is loose due to vibration.	3. See "2. Specifications" and "7. Installation."
	4. The product was damaged during transportation.	4. Please contact us.

Trouble	Cause	Solution
The product does not stop blowing.	1. Set pressure does not meet the specifications required.	1. Check the specifications. The product needs to be disassembled and some parts need to be replaced at Yoshitake. Please contact us.
	2. Insufficient sliding action of valve [4].	2. The product needs to be disassembled and the damaged parts need to be replaced by Yoshitake.
	3. Foreign substance stuck on contact surfaces of the valve [4] and valve seat [3].	3. The product needs to be disassembled and the damaged parts need to be replaced by Yoshitake.
	4. The product is installed in a wrong direction.	4. See "7. Installation."
	5. The specifications do not meet the requirements from the user.	5. See "2. Specifications" and "7. Installation."
	6. The product was damaged during transportation.	6. Please contact us.
The product does not blow out. (It does not operate.)	1. Insufficient sliding action of valve [4].	1. The product needs to be disassembled and the damaged parts need to be replaced by Yoshitake.
	2. The product is installed in the opposite direction. (The inlet and outlet are opposite.)	2. See "2. Specifications" and "7. Installation."
	3. The specifications do not meet the requirements from the user.	3. See "2. Specifications" and "7. Installation."
	4. Backpressure due to discharge collecting pipes.	4. Remove the back pressure.
	5. The product was damaged during transportation.	5. Please contact us.

Warranty Information

1. Limited warranty

This product has been manufactured using highly-advanced techniques and subjected to strict quality control. Please be sure to use the product in accordance with instructions on the manual and the label attached to it.

Yoshitake warrants the product to be free from any defects in material and workmanship under normal usage for a period of one year from the date of receipt by the original user, but no longer than 24 months from the date of shipment from Yoshitake's factory.

2. Parts supply after product discontinuation

This product may be subject to discontinuation or change for improvement without any prior notice. After the discontinuation of the product, Yoshitake supplies the repair parts for 5 years otherwise individually agreed.

3. This warranty does not cover the damage due to any of below:

- (1) Valve seat leakage or malfunction caused by foreign substances inside piping.
- (2) Improper handling or misuse.
- (3) Improper supply conditions such as abnormal water pressure/quality.
- (4) Water scale or freezing.
- (5) Trouble with power/air supply.
- (6) Any alteration made by other than Yoshitake.
- (7) Use under severe conditions deviating from the design specifications (e.g. in case of corrosion due to outdoor use).
- (8) Fire, flood, earthquake, thunder and other natural disasters.
- (9) Consumable parts such as O-ring, gasket, diaphragm and etc.

Yoshitake is not liable for any damage or loss caused by malfunction or defect of the product.

YOSHITAKE

INTERNATIONAL DEPT.

955-5, Miyamae, Irukadeshinden, Komaki, Aichi, 485-0084, Japan

Phone: +81-568-75-4432 Fax: +81-568-75-4763

E-mail: Intntl@yoshitake.co.jp