

Specification	
Fluid	
Set Press.	MPa
Temp.	℃
Flow Rate	

No.	Parts Name	Material	部品名	材質	Q. TY
27	Stud Bolt	Rolled Steel	スタッドボルト	SS400	8
26	Nut	Brass	ナット	SS400	8
25	Plug	Carbon Steel or Malleable Cast Iron	プラグ	S15C or FCMB	1
24	Set Screw	Rolled Steel	止めねじ	SCM	3
23	Spring	Alloy Steel or Spring Steel	ばね	SWOSC or SUP	1
22	Lock Nut	Brass	ロックナット	C3604	1
21	Needle Valve	Brass	背圧絞り弁	C3604	1
20	Ring Set Screw	Brass	リング止めボルト	C3604	1
19	Ring Set Screw	Brass	リング止めボルト	C3604	1
17	Nut	Brass	四面ナット	C3604	1
16	Lever Support	Cast Iron	レバー支え	FC200	1
15	Lever	Cast Iron	レバー	FC200	1
14	Lock Nut	Brass	ロックナット	C3604	1
13	Adjusting Screw	Brass	調節ねじ	C3604	1
12	Spring Plate	Cast Iron or Rolled Steel	ばね受	FC200 or SS400	2
11	Lift Set Screw	Brass	リフト制限ねじ	C3604	1
10	Lift Set Plate	Cast Iron	リフト制限板	FC200	1
9	Lift Set Ring	Brass	リフト制限リング	C3604	1
8	Spindle	Stainless Steel	スピンドル	SUS403	1
7	Valve	Stainless Steel	弁体	SUS304	1
6	Valve Guide	Bronze	バルブガイド	CAC406	1
5	Blowdown Ring	Bronze	ブローダウンリング	CAC406	1
4	Cap	Cast Iron	キャップ	FC200	1
3	Spring Chamber	Ductile Cast Iron	ばね箱	FCD450	1
2	Valve Seat	Stainless Steel	弁座	SUS420J2	1
1	Body	Ductile Cast Iron	弁箱	FCD450	1

(mm)

Size	L	H ₁	H	dt	0.785dt ²	ds	Lift	Inlet Flange JIS B 8210 10K					Outlet Flange JIS B 2239 10K					Plug No.25	Weight (kg)		
								d ₁	D ₁	C ₁	g ₁	t ₁	f ₁	n ₁ -h ₁	d ₂	D ₂	C ₂			t ₂	n ₂ -h ₂
65A	150	142	630	49	1884.7	59	11.1	65	200	160	105	30	2	8-23	90	210	175	24	8-19	R3/8	50.0
80A	165	160	682	57	2550.7	68	13.0	75	210	170	125	32	2	8-23	100	210	175	24	8-19	R3/8	62.3

※g₁寸法はJIS B 8210 10Kに準じていません。

TYPE AF-2 FULL BORE SAFETY VALVE
全量式安全弁

Approval	H. Iwamoto
Check	H. Iwamoto
Drawing	Y. Aoyama
Drawing No.	Y-054-2245-1A
Date	17 SEP. 2013



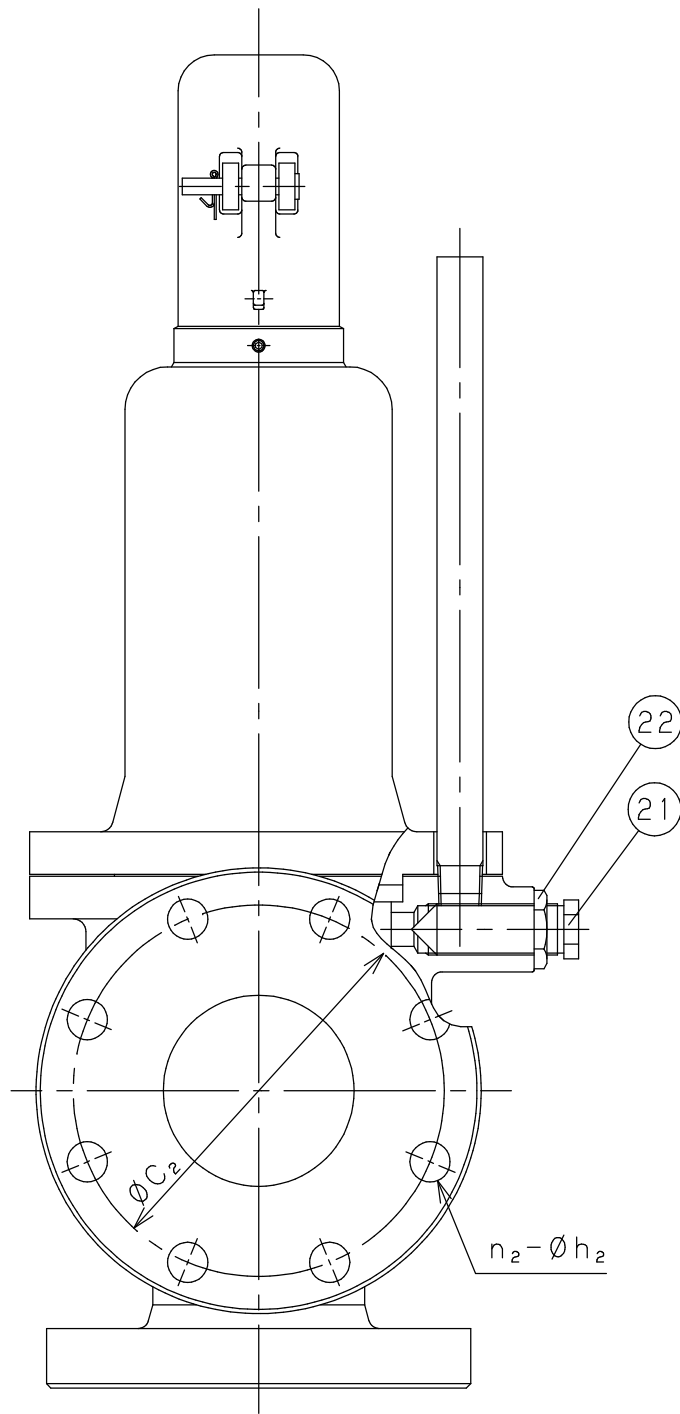
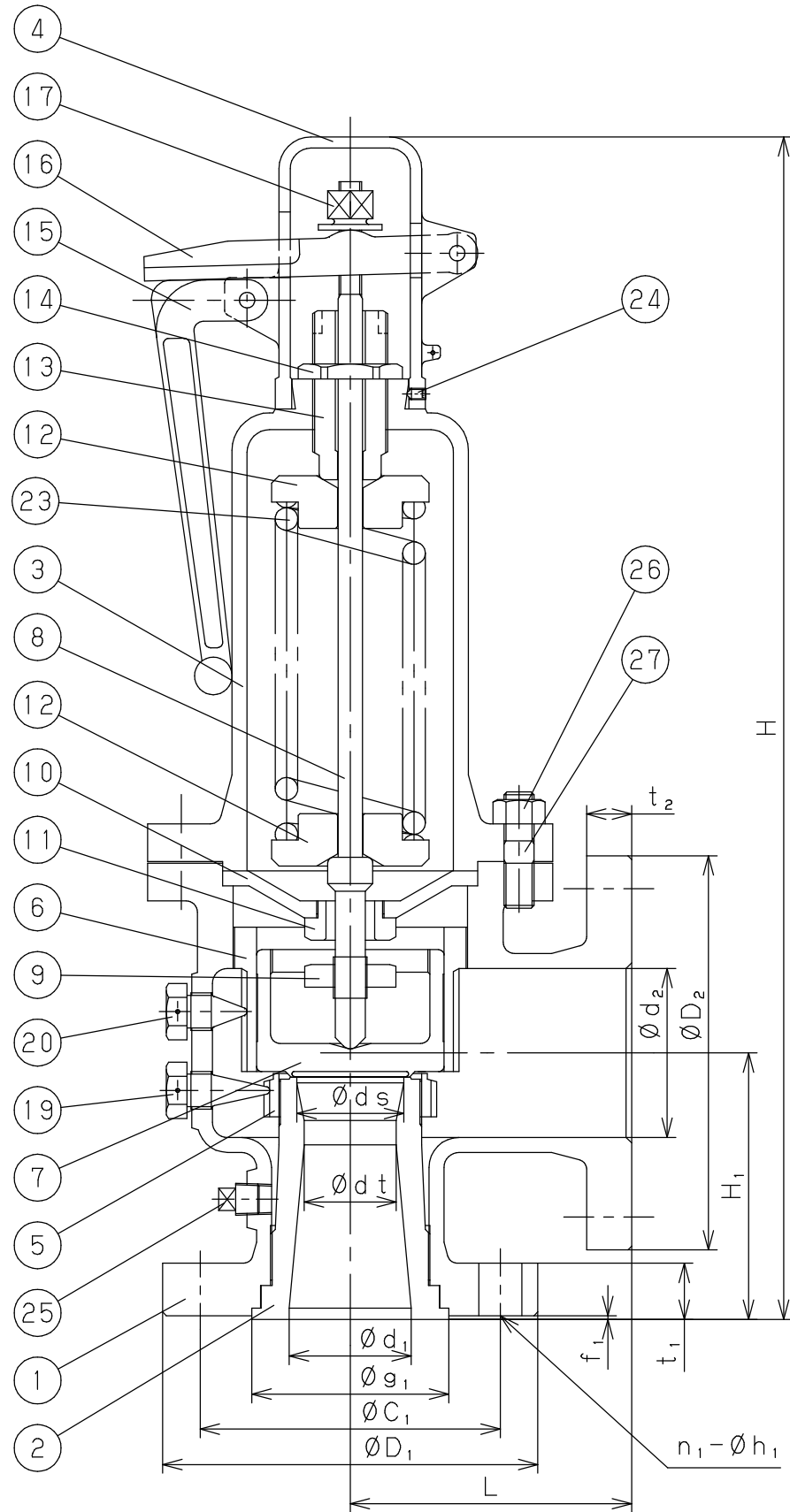

Specification	
Fluid	
Set Press.	MPa
Temp.	℃
Flow Rate	

27	Stud Bolt	Rolled Steel	スタッドボルト	SS400	8
26	Nut	Brass	ナット	SS400	8
25	Plug	Carbon Steel or Malleable Cast Iron	プラグ	S15C or FCMB	1
24	Set Screw	Rolled Steel	止めねじ	SCM	3
23	Spring	Spring Steel	ばね	SUP	1
22	Lock Nut	Brass	ロックナット	C3604	1
21	Needle Valve	Brass	背圧絞り弁	C3604	1
20	Ring Set Screw	Brass	リング止めボルト	C3604	1
19	Ring Set Screw	Brass	リング止めボルト	C3604	1
17	Nut	Brass	四面ナット	C3604	1
16	Lever Support	Cast Iron	レバー支え	FC200	1
15	Lever	Cast Iron	レバー	FC200	1
14	Lock Nut	Brass	ロックナット	C3604	1
13	Adjusting Screw	Brass	調節ねじ	C3604	1
12	Spring Plate	Cast Iron or Rolled Steel	ばね受	FC200 or SS400	2
11	Lift Set Screw	Brass	リフト制限ねじ	C3604	1
10	Lift Set Plate	Cast Iron	リフト制限板	FC200	1
9	Lift Set Ring	Brass	リフト制限リング	C3604	1
8	Spindle	Stainless Steel	スピンドル	SUS403	1
7	Valve	Stainless Steel	弁体	SUS304	1
6	Valve Guide	Bronze	バルブガイド	CAC406	1
5	Blowdown Ring	Bronze	ブローダウンリング	CAC406	1
4	Cap	Cast Iron	キャップ	FC200	1
3	Spring Chamber	Ductile Cast Iron	ばね箱	FCD450	1
2	Valve Seat	Stainless Steel	弁座	SUS420J2	1
1	Body	Ductile Cast Iron	弁箱	FCD450	1
No.	Parts Name	Material	部品名	材質	Q. TY

Size	L	H ₁	H	dt	0.785dt ²	ds	Lift	Inlet Flange JIS B 8210 20K					Outlet Flange JIS B 2239 10K					Plug No.25	Weight (kg)		
								d ₁	D ₁	C ₁	g ₁	t ₁	f ₁	n ₁ -h ₁	d ₂	D ₂	C ₂			t ₂	n ₂ -h ₂
65A	150	142	630	49	1884.7	59	11.1	65	210	170	105	30	2	8-23	90	210	175	24	8-19	R3/8	51.0
80A	165	160	682	57	2550.7	68	13.0	75	230	185	125	32	2	8-25	100	210	175	24	8-19	R3/8	64.0

※g₁寸法はJIS B 8210 20Kに準じていません。

TYPE AF-2 FULL BORE SAFETY VALVE
全量式安全弁

Approval	H. Iwamoto
Check	H. Iwamoto
Drawing	Y. Aoyama
Drawing No.	Y-054-2282-1A
Date	18 SEP. 2013

Yoshitake
INC.